

DAFTAR GAMBAR MEKAIKAL

NO.	NO GAMBAR	SKALA GAMBAR	JUDUL GAMBAR	TANGGAL DIKIRIM
1	UMUM			2022-10-23
1	EC-1001	NTS	DAFTAR GAMBAR ELEKTRONIK	●
2	AC & FAN			
A	DIAGRAM SKEMATIK			
1	AC-1101	NTS	BLOK DIAGRAM SISTEM AIR BERSIH	
B	DENAH			
1	AC-2101	1 : 300	DENAH INSTALASI AC LANTAI BASEMENT	●
2	AC-2102	1 : 300	DENAH INSTALASI AC LANTAI DASAR	●
3	AC-2103	1 : 300	DENAH INSTALASI AC LANTAI 1	●
4	AC-2104	1 : 300	DENAH INSTALASI AC LANTAI 2	●
3	AIR BERSIH			
A	DIAGRAM SKEMATIK			
1	PL-AB-1101	NTS	BLOK DIAGRAM SISTEM AIR BERSIH	
2	PL-AB-1102	NTS	BLOK DIAGRAM SISTEM KOLAM	
3	PL-AB-1103	NTS	BLOK DIAGRAM SISTEM KOLAM JACUZZI	
B	DENAH			
1	PL-AB-2101	1 : 300	DENAH INSTALASI AIR BERSIH LANTAI BASEMENT	●
2	PL-AB-2102	1 : 300	DENAH INSTALASI AIR BERSIH LANTAI DASAR	●
3	PL-AB-2103	1 : 300	DENAH INSTALASI AIR BERSIH LANTAI 1	●
4	PL-AB-2104	1 : 300	DENAH INSTALASI AIR BERSIH LANTAI 2	●
5	PL-AB-2105	1 : 300	DENAH INSTALASI AIR BERSIH ATAP	●
C	POTONGAN DAN DETAIL			
1	PL-AB-2101	1 : 200	DETAIL INSTALASI AIR BERSIH LANTAI BASEMENT	
2	PL-AB-2102	1 : 100	DETAIL INSTALASI AIR BERSIH LANTAI DASAR	
3	PL-AB-2103	1 : 50	DETAIL INSTALASI AIR BERSIH LANTAI 1	
4	AIR KOTOR			
A	DIAGRAM SKEMATIK			
1	PL-AK-1101	NTS	BLOK DIAGRAM SISTEM AIR KOTOR	
B	DENAH			
1	PL-AK-2101	1 : 300	DENAH INSTALASI AIR KOTOR LANTAI BASEMENT	●
2	PL-AK-2102	1 : 300	DENAH INSTALASI AIR KOTOR LANTAI DASAR	●
3	PL-AK-2103	1 : 300	DENAH INSTALASI AIR KOTOR LANTAI 1	●
4	PL-AK-2104	1 : 300	DENAH INSTALASI AIR KOTOR LANTAI 2	●
5				
A	DIAGRAM SKEMATIK			
1	APAR-1101	NTS	BLOK DIAGRAM APAR	●
B	DENAH			
1	APAR-2101	1 : 300	DENAH INSTALASI APAR LANTAI BASEMENT	●
2	APAR-2102	1 : 300	DENAH INSTALASI APAR LANTAI DASAR	●
3	APAR-2103	1 : 300	DENAH INSTALASI APAR LANTAI 1	●
4	APAR-2104	1 : 300	DENAH INSTALASI APAR LANTAI 2	●

REFERENSI
REFERENCE

NAMA PROJEK
PROJECT NAME

SINI SANA APARTEMEN

NO	REVISI	REVISI	TANGGAL
NO	REVISI	BY	DATE

KONSULTAN PERENCANA
CONSULTANT



PT. PADMA BUMI GAREZA

PEMILIH TUGAS
OWNER

STRUCTURE ENGINEER
DESIGNER

STRUCTURE ENGINEER

NAMA GAMBAR
DRAWING TITLE

DITAMBAH
DRAWN BY

HE D

SKALA
SCALE

AS - SHOWN

TANGGAL
DATE

03 OKTOBER 2022

NO. PROJEK
PROJECT NO.

KODE PROJEK
PROJECT CODE

KODE GAMBAR
DRAWING CODE

E. 2.01

DEVELOPER/AN OWNER

NO LEMBAR
SHEET NO.

TOTAL LEMBAR
SHEET TOTAL

DETAILING
ENGINEERING DESIGN

DAFTAR GAMBAR ELEKTRIKAL

NO.	NO GAMBAR	SKALA GAMBAR	JUDUL GAMBAR	TANGGAL DIKIRIM		
1	UMUM			2022-10-23		
1	EL-1001	NTS	DAFTAR GAMBAR ELEKTRIKAL	●		
2	DIAGRAM SKEMATIK					
1	EL-1101	NTS	BLOK DIAGRAM SISTEM DISTRIBUSI PANEL	●		
2	EL-1102	NTS	WIRING DIAGRAM PANEL LVMDP	●		
3	EL-1103	NTS	WIRING DIAGRAM PANEL SDP BASEMENT & LP. BASEMENT	●		
4	EL-1104	NTS	WIRING DIAGRAM PANEL AC BASEMENT & PP. POMPA BASEMENT	●		
5	EL-1105	NTS	WIRING DIAGRAM PANEL ELEKTRONIK	●		
6	EL-1106	NTS	WIRING DIAGRAM PANEL SDP LT. GROUND FLOOR	●		
7	EL-1107	NTS	WIRING DIAGRAM PANEL LP. LT. GROUND FLOOR	●		
8	EL-1108	NTS	WIRING DIAGRAM PANEL AC LT. GROUND FLOOR	●		
9	EL-1109	NTS	WIRING DIAGRAM PANEL SDP LT. 1	●		
10	EL-1110	NTS	WIRING DIAGRAM PANEL LP. LT. 1	●		
11	EL-1111	NTS	WIRING DIAGRAM PANEL AC LT. 1	●		
12	EL-1112	NTS	WIRING DIAGRAM PANEL SDP LT. 2	●		
13	EL-1113	NTS	WIRING DIAGRAM PANEL LP. LT. 2	●		
14	EL-1114	NTS	WIRING DIAGRAM PANEL AC LT. 2	●		
15	EL-1115	NTS	WIRING DIAGRAM PANEL SDP LT. 3	●		
16	EL-1116	NTS	WIRING DIAGRAM PANEL LP. LT. 3	●		
3	DENAH					
A	DENAH INSTALASI PENERANGAN					
1	EL-2101	1 : 300	DENAH INSTALASI PENERANGAN LANTAI BASEMENT	●		
2	EL-2102	1 : 300	DENAH INSTALASI PENERANGAN LANTAI DASAR	●		
3	EL-2103	1 : 300	DENAH INSTALASI PENERANGAN LANTAI 1	●		
4	EL-2104	1 : 300	DENAH INSTALASI PENERANGAN LANTAI 2	●		
5	EL-2105	1 : 300	DENAH INSTALASI PENERANGAN LANTAI ATAP	●		
B	DENAH INSTALASI STOP KONTAK					
1	EL-2201	1 : 300	DENAH INSTALASI STOP KONTAK LANTAI BASEMENT	●		
2	EL-2202	1 : 300	DENAH INSTALASI STOP KONTAK LANTAI DASAR	●		
3	EL-2203	1 : 300	DENAH INSTALASI STOP KONTAK LANTAI 1	●		
4	EL-2204	1 : 300	DENAH INSTALASI STOP KONTAK LANTAI 2	●		
5	EL-2205	1 : 300	DENAH INSTALASI STOP KONTAK LANTAI ATAP	●		
C	DENAH PENANGKAL PETIR					
1	EL-2301	1 : 300	DENAH INSTALASI PENANGKAL PETIR LANTAI BASEMENT	●		
2	EL-2302	1 : 300	DENAH INSTALASI PENANGKAL PETIR LANTAI ATAP	●		
4	DENAH DETAIL					
1	EL-3101	1 : 50	Polongan Dan Detail Genset	●		
2	EL-3102	1 : 50	Tampak Dan Detail Penangkal Petir	●		

REVISI
REVISION

NAMA PROJEK
PROJECT NAME

SINI SANA APARTEMEN

NO	REVISI	REVISI	TANGGAL
NO	REVISI	BY	DATE

KONSULTAN PERENCANA
CONSULTANT



PT. PADMA BUMI GAREZA

PEMERINTAH TUGAS
OWNER

STRUCTURE ENGINEER
DESIGNER

STRUCTURE ENGINEER

NAMA GAMBAR
DRAWING TITLE

DIBUAT OLEH
DRAW BY

EL D

SKALA
SCALE

AS - SHOWN

TANGGAL
DATE

03 OKTOBER 2022

NO. PROJEK PROJECT NO.	KODE PROJEK PROJECT CODE	KODE GAMBAR DRAWING CODE

E. 2. 02

DEVELOPER/OWNER ISSUED FOR	NO LEMBAR SHEET NO.	TOTAL LEMBAR SHEET TOTAL

DETAILING
ENGINEERING SECTION

DAFTAR GAMBAR ELEKTRONIK				
NO.	NO GAMBAR	SKALA GAMBAR	JUDUL GAMBAR	TANGGAL DIKIRIM
1	UMUM			2022-10-23
1	EC-1001	NTS	DAFTAR GAMBAR ELEKTRONIK	●
2	FIRE ALARM			
A	DIAGRAM SKEMATIK			
1	FA-1101	NTS	BLOK DIAGRAM SISTEM FIRE ALARM	
B	DENAH			
1	FA-2101	1 : 300	DENAH INSTALASI FIRE ALARM LANTAI BASEMENT	●
2	FA-2102	1 : 300	DENAH INSTALASI FIRE ALARM LANTAI DASAR	●
3	FA-2103	1 : 300	DENAH INSTALASI FIRE ALARM LANTAI 1	●
4	FA-2104	1 : 300	DENAH INSTALASI FIRE ALARM LANTAI 2	●
3	TELEPON			
A	DIAGRAM SKEMATIK			
1	TL-1101	NTS	BLOK DIAGRAM SISTEM TELEPON	●
B	DENAH			
1	TL-2101	1 : 300	DENAH INSTALASI TELEPON LANTAI BASEMENT	●
2	TL-2102	1 : 300	DENAH INSTALASI TELEPON LANTAI DASAR	●
3	TL-2103	1 : 300	DENAH INSTALASI TELEPON LANTAI 1	●
4	TL-2104	1 : 300	DENAH INSTALASI TELEPON LANTAI 2	●
4	CCTV DAN DATA			
A	DIAGRAM SKEMATIK			
1	CCTV-1101	NTS	BLOK DIAGRAM SISTEM CCTV DAN DATA	●
B	DENAH			
1	CCTV-2101	1 : 300	DENAH INSTALASI CCTV DAN DATA LANTAI BASEMENT	●
2	CCTV-2102	1 : 300	DENAH INSTALASI CCTV DAN DATA LANTAI DASAR	●
3	CCTV-2103	1 : 300	DENAH INSTALASI CCTV DAN DATA LANTAI 1	●
4	CCTV-2104	1 : 300	DENAH INSTALASI CCTV DAN DATA LANTAI 2	●

KETERANGAN
REFERENCE

NAMA PROJEK
PROJECT NAME

SINI SANA APARTEMEN

NO. REVISI

REVISI

NO. REVISI

DATE

KONSULTAN PERENCANA
CONSULTANT



PT. PADMA BUMI GAREZA

PEMERINTAH
OWNER

STRUCTURE ENGINEER
DESIGNER

STRUCTURE ENGINEER

NAMA GAMBAR
DRAWING TITLE

DIGAMBAR
DRAWN BY

HE D

SKALA
SCALE

AS - SHOWN

TANGGAL
DATE

03 OKTOBER 2022

NO. PROJEK
PROJECT NO.

KODE PROJEK
PROJECT CODE

KODE GAMBAR
DRAWING CODE

E. 2. 03

DEVELOPER/OWNER

ISSUED FOR

NO LEMBAR
SHEET NO.

TOTAL LEMBAR
SHEET TOTAL

DETAILING
ENGINEERING SECTION



DENAH AIR BERSIH LT. BASEMENT

SCALE 1 : 300

KETERANGAN REFERENSI			
NAMA PROJEK PROJECT NAME			
SINI SANA APARTEMEN			
NO	REVISI	REVISI	TANGGAL
NO	REVISI/DIM	BY	DATE
KONSULTAN PERENCANA CONSULTANT			
 PT. PADMA BUMI GAREZA			
PEMERINTAH TUGAS OWNER			
STRUCTURE ENGINEER KONSULTOR		STRUCTURE ENGINEER	
NAMA GAMBAR DRAWING TITLE			
DISUSUN OLEH DRAW BY		E. D	
SKALA SCALE		AS - SHOWN	
TANGGAL DATE		03 OKTOBER 2022	
NO. PROYEK PROJECT NO.	KODE PROYEK PROJECT CODE	KODE GAMBAR DRAWING CODE	
		E. CF. 01	
DEVELOPER/DOKTER ISSUED FOR		NO. LEMBAR SHEET NO.	TOTAL LEMBAR SHEET TOTAL
DETAILING ENGINEERING SECTION			

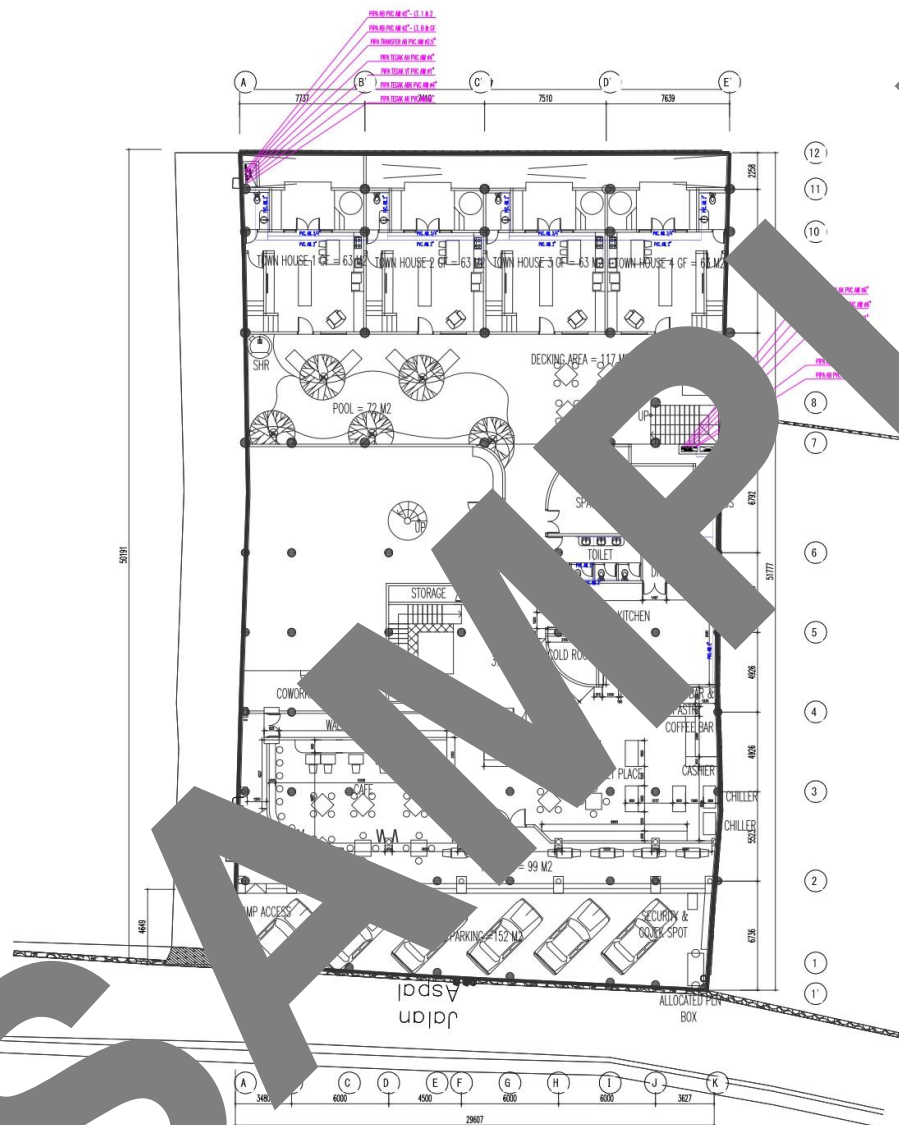

REVISI/REVISI		
REVISI		
NO. PROJEK		
PROJECT NAME		
SINI SANA APARTEMEN		
NO.	REVISI	REVISI
NO.	REVISI	DATE
KONSULTAN PERENCANA		
CONSULTANT		
 PT. PADMA BUMI GAREZA		
PEMERINTAH		
OWNER		
STRUCTURE ENGINEER	STRUCTURE ENGINEER	
DESIGNER		
NO. GAMBAR		
DRAWING TITLE		
DISUSUN	E. D.	
DISUNYAI	AS - SHOWN	
TANGGAL	03 OKTOBER 2022	
DATE		
NO. PROJEK	KODE PROJEK	KODE GAMBAR
PROJECT NAME	PROJECT CODE	DRAWING CODE
		E. CF. 02
DEVELOPER/OWNER	NO. LEMBAR	TOTAL LEMBAR
ISSUED FOR	SHEET NO.	SHEET TOTAL
DETAILING	ENGINEERING SECTION	

DENAH AIR BERSIH LT. DASAR
 SCALE 1 : 300



KETERANGAN REFERENSI			
NAMA PROJEK PROJECT NAME			
SINI SANA APARTEMEN			
NO	REVISI	REVISI	TANGGAL
NO	REVISI	BY	DATE
KONSULTAN PEENCANA CONSULTANT			
 PT. PADMA BUMI GAREZA			
PEMERINTAH KLIEN OWNER			
STRUCTURE ENGINEER KONSULTOR		STRUCTURE ENGINEER	
NAMA GAMBAR DRAWING TITLE			
DIGAMBAR DRAW BY	E. D		
SKALA SCALE	AS - SHOWN		
TANGGAL DATE	03 OKTOBER 2022		
NO. PROYEK PROJECT NO.	KODE PROYEK PROJECT CODE	KODE GAMBAR DRAWING CODE	
		E. CF. 03	
DEVELOPER/AN ORDER ISSUED FOR	NO LEMBAR SHEET NO.	TOTAL LEMBAR SHEET TOTAL	
DETAILING ENGINEERING SECTION			

DENAH AIR BERSIH LT. 1
SCALE 1 : 300



SAMPLE

SAMPLE

REVISION
REFERENCE

NAMA PROJEK
PROJECT NAME

SINI SANA APARTEMEN

NO	REVISI	REVISI	TANGGAL
NO	REVISI	BY	DATE

KONSULTAN PERENCANA
CONSULTANT



PT. PADMA BUMI GAREZA

PERENCANA
OWNER

STRUCTURE ENGINEER
DESIGNER

STRUCTURE ENGINEER

NAMA GAMBAR
DRAWING TITLE

DITAMBAH
DRAW BY

EH D

SKALA
SCALE

AS - SHOWN

TANGGAL
DATE

03 OKTOBER 2022

NO. PROJEK
PROJECT NO.

KODE PROJEK
PROJECT CODE

KODE GAMBAR
DRAWING CODE

E. CF. 04

DEVELOPER/OWNER

NO. LEMBAR
SHEET NO.

TOTAL LEMBAR
SHEET TOTAL

DETAILING
ENGINEERING SECTION

DENAH AIR BERSIH LT. 2

SCALE 1 : 300

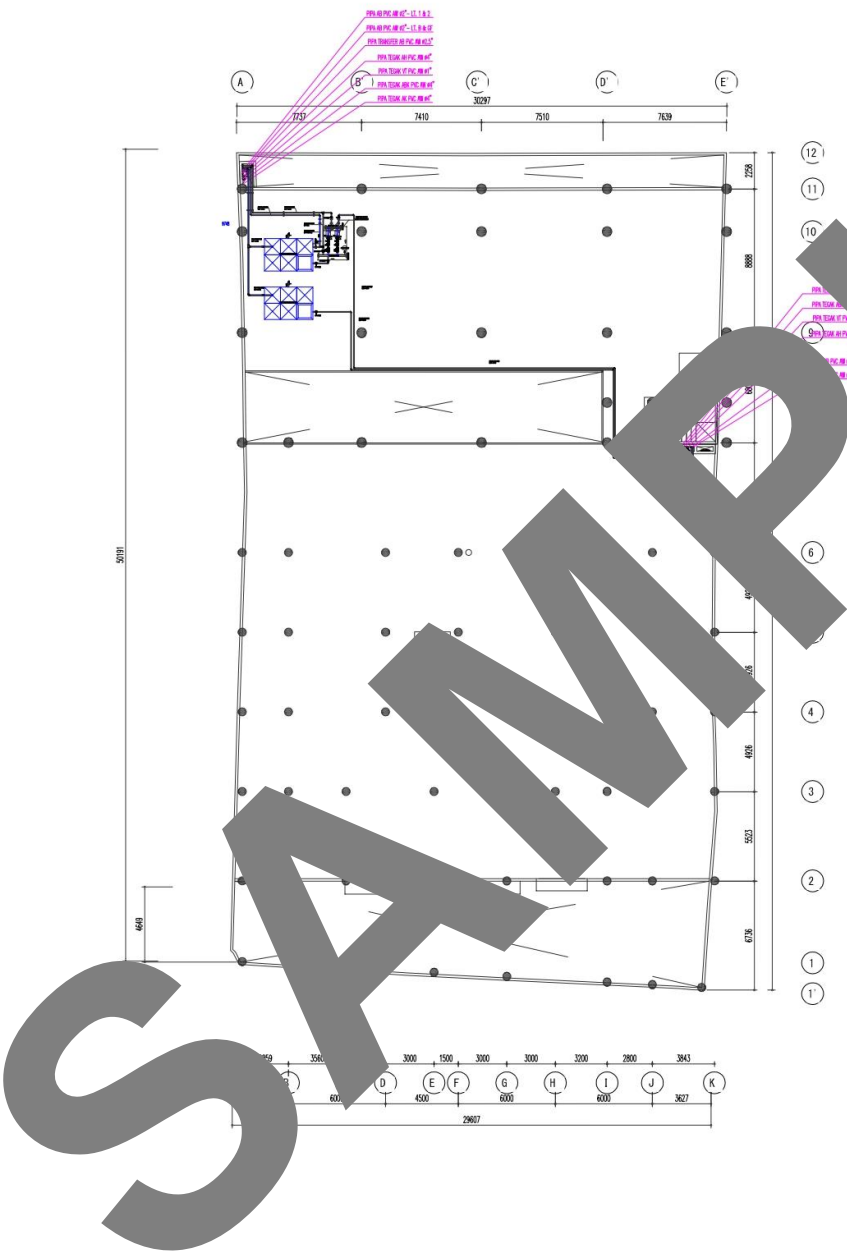

DENAH AIR BERSIH LT. 2

SCALE 1 : 300

KETERANGAN REFERENSI		
NAMA PROJEK PROJECT NAME		
SINI SANA APARTEMEN		
NO	REVISI	REVISI
NO	REVISI	DATE
KONSULTAN PERENCANA CONSULTANT		
 PT. PADMA BUMI GAREZA		
PEMERINTAH TUGAS OWNER		
STRUCTURE ENGINEER	STRUCTURE ENGINEER	
NAMA GAMBAR DRAWING TITLE		
DIGAMBAR DRAW BY	E. D	
SKALA SCALE	AS - SHOWN	
TANGGAL DATE	03 OKTOBER 2022	
NO. PROJEK PROJECT NO.	KODE PROJEK PROJECT CODE	KODE GAMBAR DRAWING CODE
		E. CF. 04
DEVELOPER/AN ORDER	NO LEMBAR SHEET NO.	TOTAL LEMBAR SHEET TOTAL
DETAILING ENGINEERING SECTION		

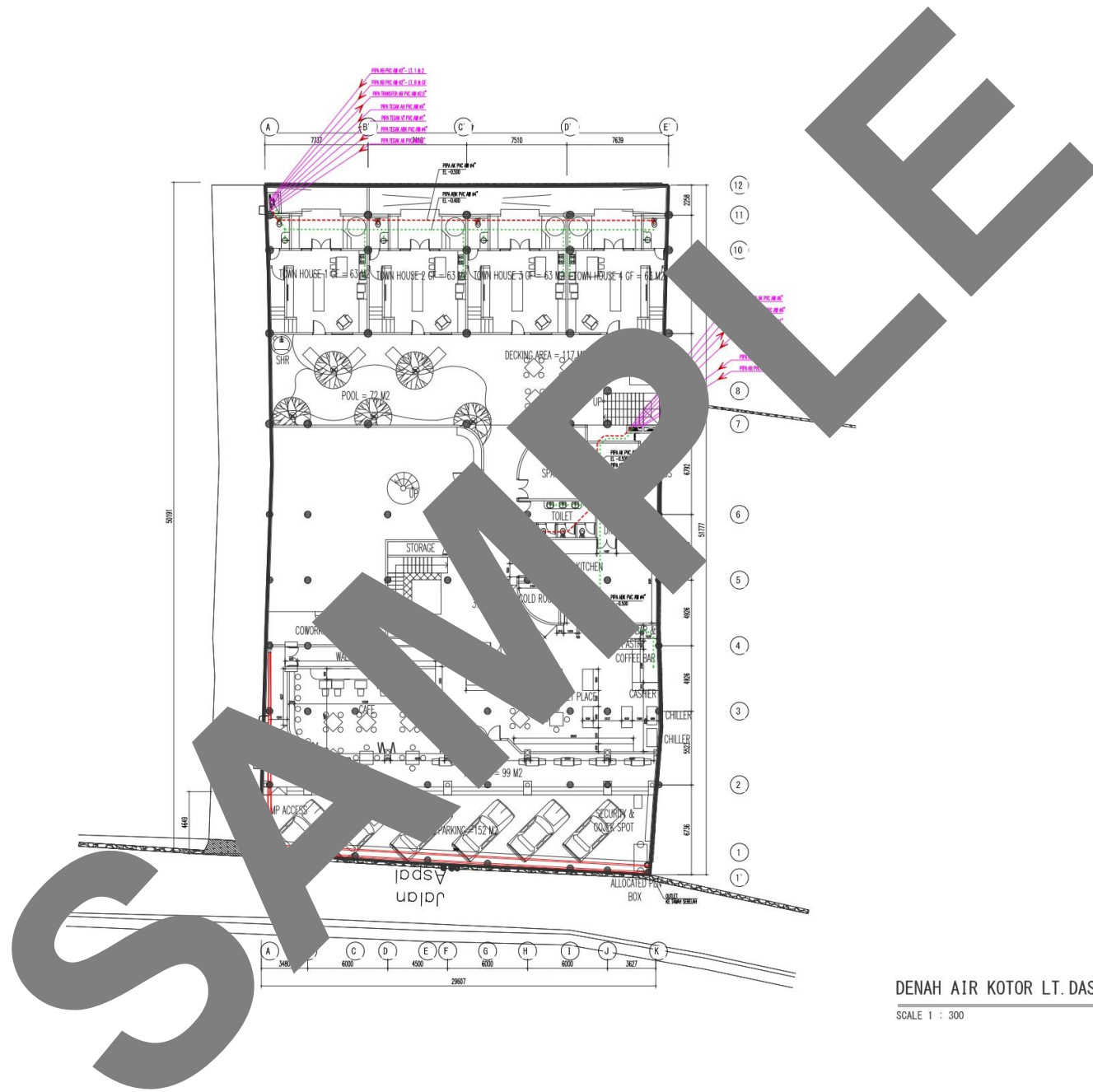

REVISION/REFERENCE			
NAMA PROJEK PROJECT NAME SINI SANA APARTEMEN			
NO	REVISI	REVISI	TANGGAL
NO	REVISI/DIM	BY	DATE
KONSULTAN/PEKERJA KONSULTAN			
 PT. PADMA BUMI GAREZA			
PEMERINTAH/PEKERJA			
OWNER			
STRUCTURE ENGINEER		STRUCTURE ENGINEER	
KONSULTAN		KONSULTAN	
NAMA GAMBAR DRAWING TITLE			
DISUSUN OLEH	E. D		
SKALA	AS - SHOWN		
TANGGAL	03 OKTOBER 2022		
DATE	03 OKTOBER 2022		
NO. PROJEK	KODE PROJEK	KODE GAMBAR	
PROJECT NAME	PROJECT CODE	DRAWING CODE	
		E. CF. 02	
DEVELOPER/OWNER		NO. LEMBAR	TOTAL LEMBAR
ISSUED FOR		SHEET NO.	SHEET TOTAL
DETAILING/ENGINEERING SECTION			

DENAH AIR KOTOR LT. DASAR
 SCALE 1 : 300



DENAH AIR KOTOR LT. 1

SCALE 1 : 300

REVISI REFERENSI			
NAMA PROJEK PROJECT NAME			
SINI SANA APARTEMEN			
NO	REVISI	REVISI	TANGGAL
NO	REVISI	BY	DATE
KONSULTAN PEENCANA CONSULTANT			
 PT. PADMA BUMI GAREZA			
PEMERINTAH TUGAS OWNER			
STRUCTURE ENGINEER KONSULTOR		STRUCTURE ENGINEER	
NAMA GAMBAR DRAWING TITLE			
DITAMBAH DRAW BY		E. D	
SKALA SCALE		AS - SHOWN	
TANGGAL DATE		03 OKTOBER 2022	
NO. PROYEK PROJECT NO.	KODE PROJEK PROJECT CODE	KODE GAMBAR DRAWING CODE	
		E. CF. 03	
DEVELOPER/AN ORDER ISSUED FOR		NO LEMBAR SHEET NO.	TOTAL LEMBAR SHEET TOTAL
DETAILING ENGINEERING SECTION			



SAMPLE

KETERANGAN REFERENSI		
NAMA PROJEK PROJECT NAME SINI SANA APARTEMEN		
NO. REVISI	REVISI	TANGGAL
NO. REVISI/DW	BY	DATE
KONSULTAN PEENCANA CONSULTANT <div style="text-align: center;">  PT. PADMA BUMI GAREZA </div>		
PEMERINTAH TUGAS OWNER <div style="display: flex; justify-content: space-between;"> <div style="width: 45%;"> STRUCTURE ENGINEER KONSULTOR </div> <div style="width: 45%;"> STRUCTURE ENGINEER </div> </div>		
NAMA GAMBAR DRAWING TITLE DISAMBAR DEKOR BY SKALA SCALE TANGGAL DATE		
H. D AS - SHOWN 03 OKTOBER 2022		KODE GAMBAR DRAWING CODE E. CF. 04
NO. PROJEK PROJECT NAME	KODE PROJEK PROJECT CODE	KODE GAMBAR DRAWING CODE
DEKORASI DAN DOKUMEN	NO. LEMBAR SHEET NO.	TOTAL LEMBAR SHEET TOTAL
DETAILING ENGINEERING SECTION		

DENAH AIR KOTOR LT. 2

SCALE 1 : 300

GENSET 1
100 kVA SILENT
380V/3PH/50Hz



PANEL

SDP-LT. ATAP

PP-MESIN LIFT
(BY LIFT)
PP-POMPA

SDP-LT. 2

LP-LT. 2
LP-PENTHOUSE 2
PP-AC. 1

1

LP-LT. 1
PP-AC. LANTAI 1

SDP-LT. DASAR

LP-LT. DASAR
PP-AC. LANTAI DASAR

SDP-LT. BASEMENT

LP-BASEMENT
PP-AC
PP-POMPA UTILITY
PP-ELEKTRONIK



DARI PLN



REVISI/REVISION			
NO. PROJEK PROJECT NO.			
SINI SANA APARTEMEN			
NO.	REVISI	REVISI	TANGGAL
NO.	REVISI	BY	DATE
KONSULTAN PERENCANA CONSULTANT			
 PT. PADMA BUMI GAREZA			
PEMILIH/TUGAS OWNER			
STRUCTURE ENGINEER KONSULTAN		STRUCTURE ENGINEER	
NO. GAMBAR DRAWING TITLE			
DISENIBAR DRAWN BY	E. D		
SKALA SCALE	AS - SHOWN		
TANGGAL DATE	03 OKTOBER 2022		
NO. PROJEK PROJECT NO.	KODE PROJEK PROJECT CODE	KODE GAMBAR DRAWING CODE	
		E. 2. 01	
DEVELOPER/OWNER TUGAS/NO	NO. LEMBAR SHEET NO.	TOTAL LEMBAR SHEET TOTAL	
DETAILING ENGINEERING SECTION			

NO	STATUS	GB	CB1	CB2
1	PLN NORMAL	OFF	ON	OFF
2	PLN BLACK OUT	ON	ON	ON
3	PLN + GB BLACK OUT	OFF	OFF	OFF

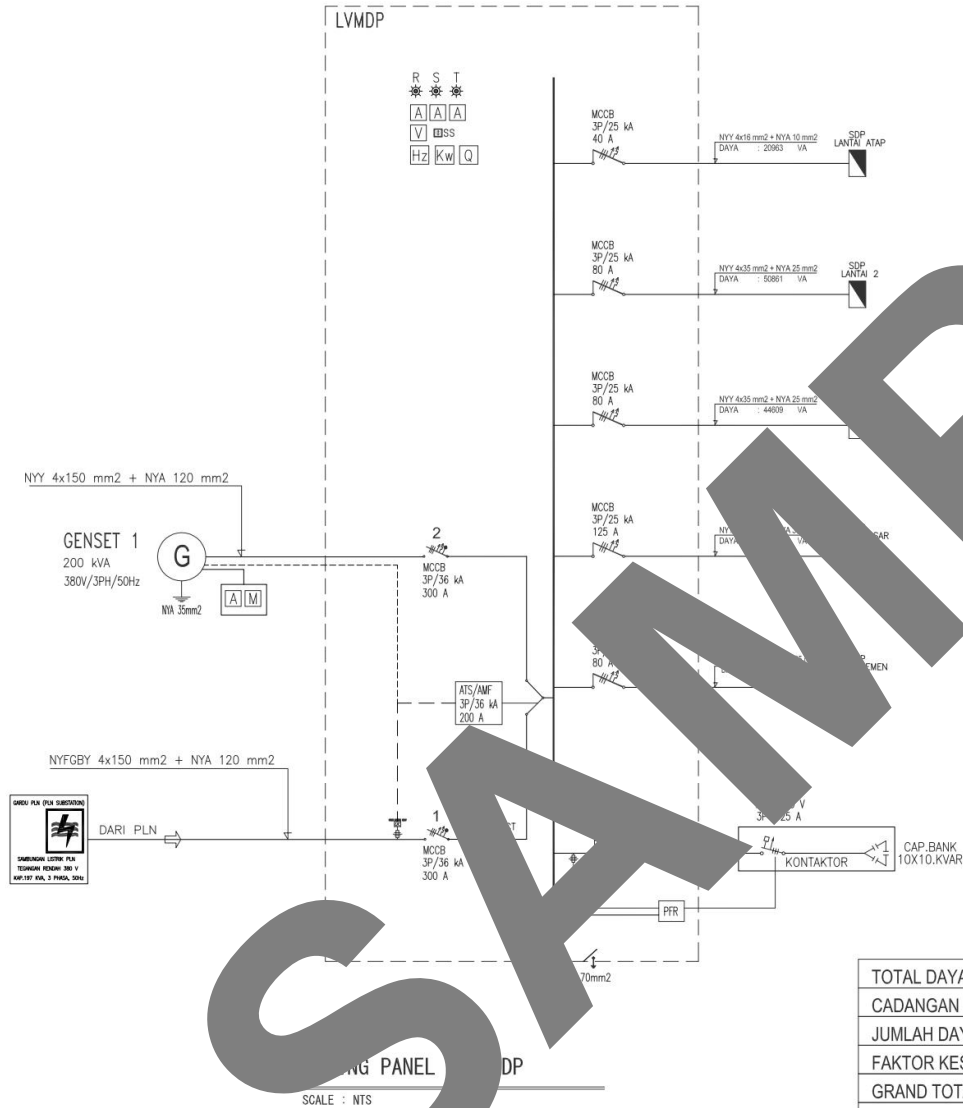

TOTAL DAYA		227688 VA	135528 VA
CADANGAN + 5 %	0.05	11384 VA	6776 VA
JUMLAH DAYA		239072 VA	142304 VA
FAKTOR KESEREMPAKAN		0.8 VA	0.8 VA
GRAND TOTAL DAYA		191258 VA	113843 VA
		191.258 kVA	113.843 kVA
FAKTOR EFISIENSI			1.2
SAMBUNGAN DAYA PLN		197 kVA	
DAYA GENSET - 1 (NEW)			135 kVA

PLN	VA		
20963 VA			
50861 VA	29486 VA		
44609 VA	22671 VA		
69216 VA	34341 VA		
42692 VA	28067 VA		

REVISION

REFERENCE

NAMA PROJEK

PROJECT NAME

SINI SANA APARTEMEN

NO

REVISI

NO

REVISI

REVISI

REVISI

REVISI

REVISI

REVISI

REVISI

REVISI

REVISI

REVISI

REVISI

REVISI

REVISI

REVISI

REVISI

REVISI

REVISI

REVISI

REVISI

REVISI

REVISI

REVISI

REVISI

REVISI

REVISI

REVISI

REVISI

REVISI

REVISI

REVISI

REVISI

REVISI

REVISI

REVISI

REVISI

REVISI

REVISI

REVISI

REVISI

REVISI

REVISI

REVISI

REVISI

REVISI

REVISI

REVISI

REVISI

REVISI

REVISI

REVISI

REVISI

REVISI

REVISI

REVISI

REVISI

REVISI

REVISI

REVISI

REVISI

REVISI

REVISI

REVISI

REVISI

REVISI

REVISI

REVISI

REVISI

REVISI

REVISI

REVISI

REVISI

REVISI

REVISI

REVISI

REVISI

REVISI

REVISI

REVISI

REVISI

REVISI

REVISI

REVISI

REVISI

REVISI

REVISI

REVISI

REVISI

REVISI

REVISI

REVISI

REVISI

REVISI

REVISI

REVISI

REVISI

REVISI

REVISI

REVISI

REVISI

REVISI

REVISI

REVISI

REVISI

REVISI

REVISI

REVISI

REVISI

REVISI

REVISI

REVISI

REVISI

REVISI

REVISI

REVISI

REVISI

REVISI

REVISI

REVISI

REVISI

REVISI

REVISI

REVISI

REVISI

REVISI

REVISI

REVISI

REVISI

REVISI

REVISI

REVISI

REVISI

REVISI

REVISI

REVISI

REVISI

REVISI

REVISI

REVISI

REVISI

REVISI

REVISI

REVISI

REVISI

REVISI

REVISI

REVISI

REVISI

REVISI

REVISI

REVISI

REVISI

REVISI

REVISI

REVISI

REVISI

REVISI

REVISI

REVISI

REVISI

REVISI

REVISI

REVISI

REVISI

REVISI

REVISI

REVISI

REVISI

REVISI

REVISI

REVISI

REVISI

REVISI

REVISI

REVISI

REVISI

REVISI

REVISI

REVISI

REVISI

REVISI

REVISI

REVISI

REVISI

REVISI

REVISI

REVISI

REVISI

REVISI

REVISI

REVISI

REVISI

REVISI

REVISI

REVISI

REVISI

REVISI

REVISI

REVISI

REVISI

REVISI

REVISI

REVISI

REVISI

REVISI

REVISI

REVISI

REVISI

REVISI

REVISI

REVISI

REVISI

REVISI

REVISI

REVISI

REVISI

REVISI

REVISI

REVISI

REVISI

REVISI

REVISI

REVISI

REVISI

REVISI

REVISI

REVISI

REVISI

REVISI

REVISI

REVISI

REVISI

REVISI

REVISI

REVISI

REVISI

REVISI

REVISI

REVISI

REVISI

REVISI

REVISI

REVISI

REVISI

REVISI

REVISI

REVISI

REVISI

REVISI

REVISI

REVISI

REVISI

REVISI

REVISI

REVISI

REVISI

REVISI

REVISI

REVISI

REVISI

REVISI

SUB DISTRIBUTION PANEL LT. BASEMENT (SDP. BASEMENT)

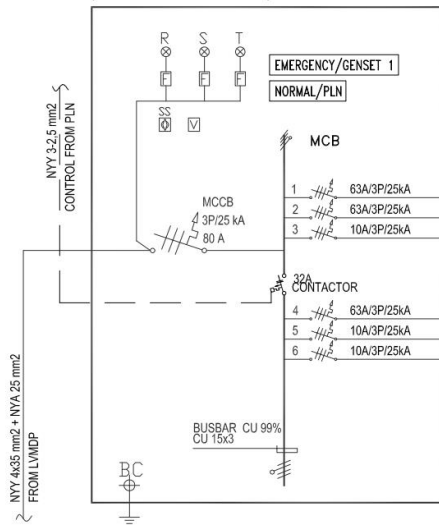

UKURAN KABEL	LOAD	LOAD VA	TOTAL LOAD		
			R	S	T
NY 4x6 mm2 + NYA 6 mm2	LP - LT. BASEMENT	10179	3393	3393	3393
NY 4x6 mm2 + NYA 6 mm2	PP - POMPA LT. BASEMENT	10388	3463	3463	3462
NY 4x6 mm2 + NYA 6 mm2	PP - ELEKTRONIK	7500	2500	2500	2500
NY 4x10 mm2 + NYA 10 mm2	PP - AC LT. BASEMENT	14625	4875	4875	4875
	SPARE				
	SPARE				
			14231		
			PLN		
			GENSET	28067	VA

WIRING PANEL - SDP BASEMENT

SCALE : NTS

LIGHTING PANEL LT. BASEMENT (LP. BASEMENT)

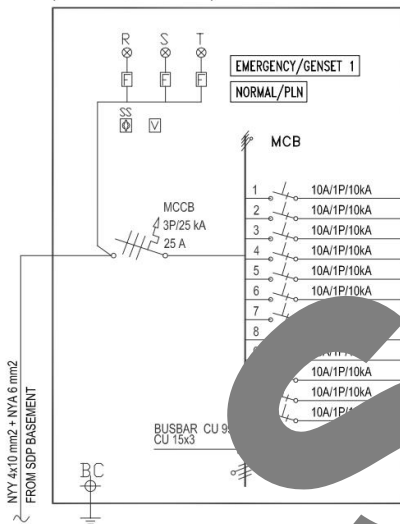

UKURAN KABEL	GROUP	DL LED 15 W	TL LED 15 W	WL LED 15 W	TL LED 18 W	TL LED + NICAD 18 W	EF. 200 CFM 50 W	STC.16A 250 W	SWITC. 2	SWITC. 4	DAYA (WATT)		
											R	S	T
NY 3x4 mm2					6	2	3		14	1	294		
NY 3x4 mm2		32	10		20	9			4	1		1152	
NY 3x4 mm2		35	10	8	10	4	3		5	3			1197
NY 3x4 mm2								6			1500		
NY 3x4 mm2								6				1500	
NY 3x4 mm2								3					750
NY 3x4 mm2								3			750		
NY 3x4 mm2								4					1000
	SPARE												
	SPARE												
	SPARE												
	SPARE												
		75	20	8	36	15	6	18	23	5	2544	2652	2947
											TOTAL DAYA = 8143	WATT	
											TOTAL DAYA = 15	A	
											TOTAL DAYA = 10179	VA	

WIRING PANEL - LP - BASEMENT

SCALE : NTS

REVISION
REFERENCE

NO. REVISI
NO. REVISI

REVISI
BY
DATE

KONSULTAN PEKERJA
CONSULTANT

PADMA
STRUKTUR

PT. PADMA BUMI GAREZA

PERMITS
OWNER

STRUCTURE ENGINEER
DESIGNER

STRUCTURE ENGINEER

NO. PROJEK
PROJECT NO.

KODE GAMBAR
DRAWING CODE

DISAMBAH
DESKRIPSI
SKALA
SCALE
TANGGAL
DATE

HE D
AS - SHOWN
03 OKTOBER 2022

NO. PROJEK
PROJECT NO.

KODE GAMBAR
DRAWING CODE

E. 2. 01

DEVELOPER/OWNER
ISSUED FOR

NO. LEMBAR
SHEET NO.

TOTAL LEMBAR
SHEET TOTAL

DETAILING
ENGINEERING SECTION

PANEL AC LT. BASEMENT
(LP. BASEMENT)

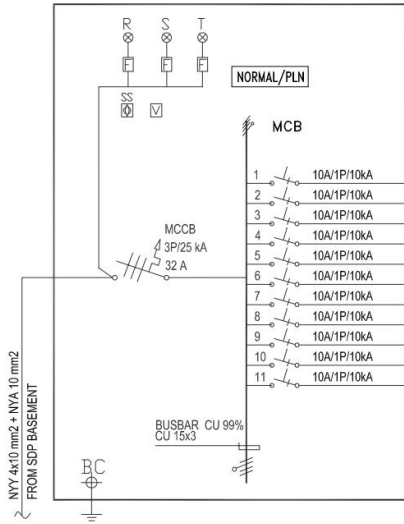

UKURAN KABEL	GROUPING	AC. 1 PK 900 W	AC. 2 PK 1800 W	DAYA (WATT)		
				R	S	T
NY 3x4 mm2	AC.B.A		1	1800		
NY 3x4 mm2	AC.B.B		1		1800	
NY 3x4 mm2	AC.B.C		1			1800
NY 3x4 mm2	AC.B.D	1		900		
NY 3x4 mm2	AC.B.E		1		1800	
NY 3x4 mm2	AC.B.F		1			
NY 3x4 mm2	AC.B.G	1		900		
NY 3x4 mm2	AC.B.H	1		900		
	SPARE					
	SPARE					
	SPARE					
		3	5	4500	4500	4500
				TOTAL DAYA	= 1800	WATT
				TOTAL DAYA	= 2700	VA
				TOTAL DAYA	= 4500	VA

WIRING PANEL - AC BASEMENT

SCALE : NTS

POWER
PP-POMPA

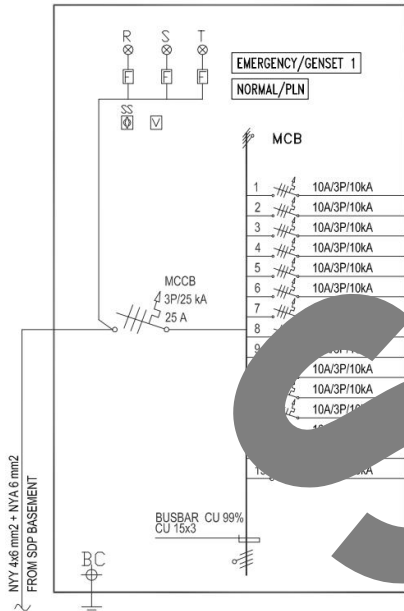

UKURAN KABEL	GROUPING	POMPA	DAYA (WATT)		
			R	S	T
NY 4x4 mm2	SWT. RUN	1	250	250	250
NY 4x4 mm2	STAND BY	1			
NY 4x4 mm2	POMPA	1	135	135	135
NY 4x4 mm2	POMPA	1			
NY 4x4 mm2	SWT. (LT-040) STP. STAND BY	1	500	500	500
NY 4x4 mm2 + NYA 4 mm2	POMPA DRAINASE 1. RUN	1	250	250	250
NY 4x4 mm2 + NYA 4 mm2	POMPA DRAINASE 1. STAND BY	1			
NY 4x4 mm2 + NYA 4 mm2	POMPA DRAINASE 2. RUN	1	250	250	250
NY 4x4 mm2 + NYA 4 mm2	POMPA DRAINASE 2. STAND BY	1			
NY 4x4 mm2 + NYA 4 mm2	POMPA POOL . RUN	1	250	250	250
NY 4x4 mm2 + NYA 4 mm2	POMPA POOL STAND BY	1			
	SPARE				
	SPARE				
	SPARE				
			1635	1635	1635
			TOTAL DAYA	= 4905	WATT
			TOTAL DAYA	= 9	A
			TOTAL DAYA	= 6131	VA

WIRING PANEL - POMPA BASEMENT

SCALE : NTS

REVISION
REFERENCE

NO. PROJEK
PROJECT NAME

SINI SANA APARTEMEN

NO. REVISI	REVISI	TANGGAL
NO. REVISI	REVISI	DATE

KONSULTAN PERENCANA
CONSULTANT

PADMA
STRUKTUR

PT. PADMA BUMI GAREZA

PERMITS
OWNER

STRUCTURE ENGINEER	DESIGNER	STRUCTURE ENGINEER
--------------------	----------	--------------------

NO. GAMBAR
DRAWING TITLE

DISAMBAH
DRAW BY: H. D

SKALA
SCALE: AS - SHOWN

TANGGAL
DATE: 03 OKTOBER 2022

NO. PROJEK	KODE PROJEK	KODE GAMBAR
PROJECT NO.	PROJECT CODE	DRAWING CODE

E. 2.01

DEVELOPER/DRAWN BY	NO. LEMBAR	TOTAL LEMBAR
DRAWN BY	SHEET NO.	SHEET TOTAL

DETAILING
ENGINEERING SECTION

PANEL POWER ELEKTRONIK
(PP. ELECTONIK)

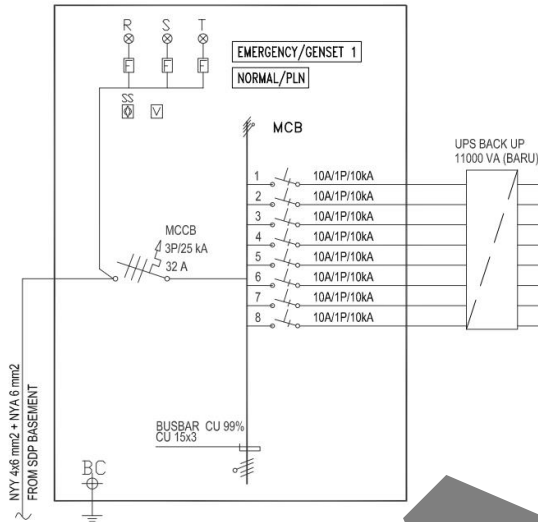

UKURAN KABEL	MAG	DAYA (WATT)	
		S	T
1 NY 3x4 mm2	MAIN FIRE	600	
2 NY 3x4 mm2	MAIN CCTV		
3 NY 3x4 mm2	MAIN SOUND SYSTEM	1200	
4 NY 3x4 mm2	TELEFON	1200	1200
5 NY 3x4 mm2	PERANGKATAN DATA	1200	
	SPARE PART		
	SPARE PART		
		2400	1200
TOTAL DAYA = 6000		WATT	
TOTAL DAYA = 11		A	
TOTAL DAYA = 7500		VA	

WIRING PANEL – ELEKTRONIK

SCALE : NTS

SAMPLE

KETERANGAN REFERENCE		
NOMOR PROJEK PROJECT NO		
SINI SANA APARTEMEN		
NO. REVISI	REVISI	TANGGAL
NO. REVISI	BY	DATE
KONSULTAN PERENCANA CONSULTANT		
 PT. PADMA BUMI GAREZA		
PEMERINTAH OWNER		
STRUCTURE ENGINEER KONSULTOR	STRUCTURE ENGINEER	
NOMOR GAMBAR DRAWING TITLE		
DISENIBAR DRAW BY	E. D	
SKALA SCALE	AS – SHOWN	
TANGGAL DATE	03 OKTOBER 2022	
NO. PROJEK PROJECT NO	KODE PROJEK PROJECT CODE	KODE GAMBAR DRAWING CODE
		E. 2. 01
DEVELOPER/DOKTER ISSUED FOR	NO. LEMBAR SHEET NO	TOTAL LEMBAR SHEET TOTAL
DETAILING ENGINEERING SECTION		

SUB DISTRIBUTION PANEL LT. GF
(SDP. LT. GF)

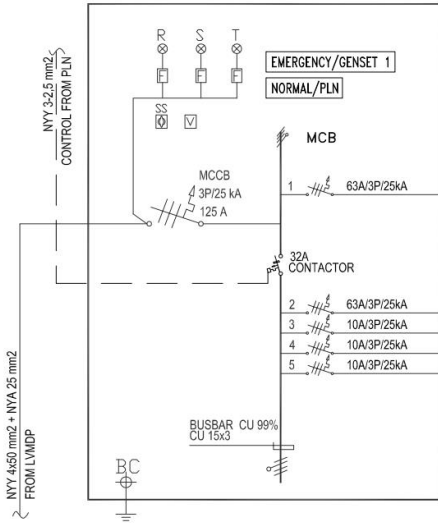

UKURAN KABEL	LOAD	LOAD	TO
NYA 4x25 mm2 + NYA 16 mm2	LP - LT. LT. GF	11447	11447
NYA 4x25 mm2 + NYA 16 mm2	PP - A	11625	11625
	SPARE		
	SPARE		
	SPARE		
		23072	23072
		23072	23072
	PLN	= 69216	VA
	GENSET 1	= 34341	VA

WIRING PANEL – SDP LT. GF

SCALE : NTS

SAMPLE

REVISION REFERENCE		
NO. PROJEK PROJECT NAME		
SINI SANA APARTEMEN		
NO. REVISI	REV.	TANGGAL
NO. REVISI/UM	BY	DATE
KONSULTAN PERENCANA CONSULTANT		
 PT. PADMA BUMI GAREZA		
PEMERINTAH OWNER		
STRUCTURE ENGINEER KONSTRUKTOR		STRUCTURE ENGINEER
NO. GAMBAR DRAWING TITLE		
DISUSUN OLEH DRAW BY	E. D	
SKALA SCALE	AS - SHOWN	
TANGGAL DATE	03 OKTOBER 2022	
NO. PROJEK PROJECT NO.	KODE PROJEK PROJECT CODE	KODE GAMBAR DRAWING CODE
		E. 2. 01
DEVELOPER/OWNER TUGAS / JOB	NO. LEMBAR SHEET NO.	TOTAL LEMBAR SHEET TOTAL
DETAILING ENGINEERING SECTION		

LIGHTING PANEL LT. GF
(LP. LT. GF)

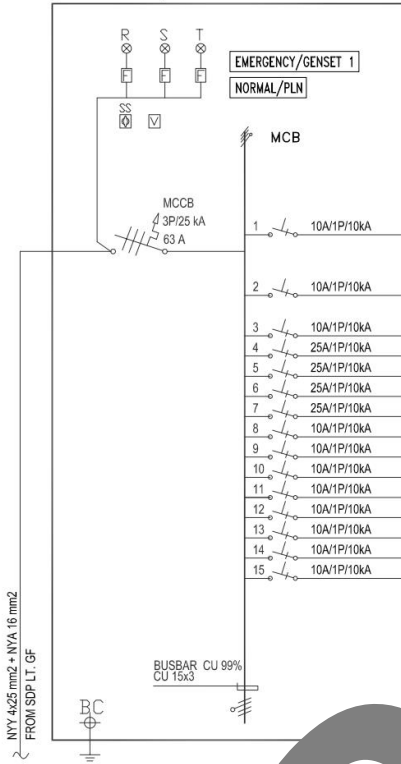

UKURAN KABEL	GROUPING	DL. LED 15 W	DL. LED + NICAD 15 W	PDL. LED 15 W	NICAD 18 W	STC.16A 250 W	SW	LZ 300 W	DAYA (WATT)				
									R	S	T		
NYY 3x4 mm2	L.D.A	10	6				1		240				
	L.D.B	10	6						345				
	L.D.C	8	4	3			1		270				
NYY 3x4 mm2	S.D.D	8					1			165			
	L.D.E	8		4			1			243			
	L.D.F	8					1			180			
NYY 3x4 mm2	L.D.G				4		1				300		
	L.D.H				8						120		
NYY 3x4 mm2	L.D.T.H.A	17			13		12	11	1	4590			
	L.D.T.H.B	17					12	11	1	4590			
NYY 3x4 mm2	L.D.T.H.C	17			8		12	11	1		4590		
	L.D.T.H.D	17			8		12	11	1	4590			
NYY 3x4 mm2	S.A						5			1250			
	S.B						5				1250		
NYY 3x4 mm2	S.C						7			1750			
	S.D						7				1750		
NYY 3x4 mm2	S.E						5				1250		
	SPARE												
NYY 3x4 mm2	SPARE												
	SPARE												
		130	64	46	67	1	12	77	50	1	10035	8178	9260
									TOTAL DAYA = 27473 WATT				
									TOTAL DAYA = 52 A				
									TOTAL DAYA = 34341 VA				

WIRING PANEL - LP - LT. GF

SCALE : NTS

REVISI
REFERENSI

NO. PROJEK
PROJECT NAME

SINI SANA APARTEMEN

NO. REVISI	REVISI	TANGGAL
NO. REVISI	BY	DATE

KONSULTAN PEKERJAAN
CONSULTANT

PADMA STRUKTUR
PT. PADMA BUMI GAREZA

PEMERINTAH TUGAS
OWNER

STRUCTURE ENGINEER KONSULTAN	STRUCTURE ENGINEER

NO. GAMBAR
DRAWING TITLE

DITAMBAH
DESKRIPSI

DESKRIPSI

SKALA
SCALE

TANGGAL
DATE

03 OKTOBER 2022

NO. PROJEK PROJECT NAME	KODE GAMBAR DRAWING CODE
	E. 2.01

DEVELOPER/OWNER	NO. LEMBAR SHEET NO.	TOTAL LEMBAR SHEET TOTAL

DETAILING
ENGINEERING SECTION

PANEL AC LT. GF
(LP. LT. GF)

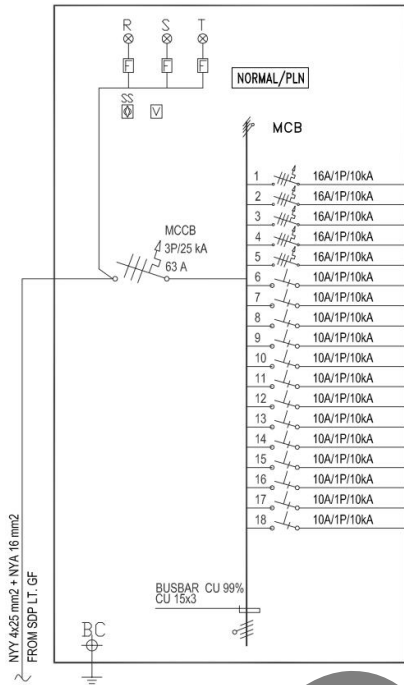

UKURAN KABEL	GROUPING	AC. 0.5 PK 450 W	AC. 4 PK 3600 W	AC. 5 PK 4500 W	DAYA (W)		
					S	V	VA
1	16A/1P/10kA	NY 4x4 mm2 + NYA 4 mm2	AC.D.A		1500	1500	1500
2	16A/1P/10kA	NY 4x4 mm2 + NYA 4 mm2	AC.B.B		1200	1200	1200
3	16A/1P/10kA	NY 4x4 mm2 + NYA 4 mm2	AC.B.C		1200	1200	1200
4	16A/1P/10kA	NY 4x4 mm2 + NYA 4 mm2	AC.B.D		1200	1200	1200
5	16A/1P/10kA	NY 4x4 mm2 + NYA 4 mm2	AC.B.E		1200	1200	1200
6	10A/1P/10kA	NY 3x4 mm2	AC.B.F	1			900
7	10A/1P/10kA	NY 3x4 mm2	AC.B.G		900		
8	10A/1P/10kA	NY 3x4 mm2	AC.B.H		900		
9	10A/1P/10kA	NY 3x4 mm2	AC.B.I				900
10	10A/1P/10kA	NY 3x4 mm2	AC.B.J		900		
11	10A/1P/10kA	NY 3x4 mm2	AC.B.K	1			900
12	10A/1P/10kA	NY 3x4 mm2	AC.B.L				900
13	10A/1P/10kA	NY 3x4 mm2	AC.B.M	2			900
14	10A/1P/10kA	NY 3x4 mm2	AC.B.N				900
15	10A/1P/10kA	NY 3x4 mm2	AC.B.O				900
16	10A/1P/10kA	SPARE					
17	10A/1P/10kA	SPARE					
18	10A/1P/10kA	SPARE					
					9000	9000	9000
TOTAL DAYA =					27900	WATT	
TOTAL DAYA =					53	A	
TOTAL DAYA =					34875	VA	

WIRING PANEL - AC LT. GF

SCALE : NTS

REVISI/REVISI

NO. REVISI: REVISI: TANGGAL:

NO. REVISI/NO. BY: DATE:

KONSULTAN PERENCANAAN
CONSULTANT

PADMA
STRUKTUR

PT. PADMA BUMI GAREZA

PERENCANAAN
OWNER:

STRUCTURE ENGINEER STRUCTURE ENGINEER

NO. PROJEK KODE PROJEK KODE GAMBAR

PROJECT NAME PROJECT CODE DRAWING CODE

E. 2.01

DEVELOPER/OWNER NO. LEMBAR TOTAL LEMBAR

ISSUED FOR SHEET NO. SHEET TOTAL

DETAILING
ENGINEERING SECTION

LIGHTING PANEL LT. 1
(LP. LT. 1)

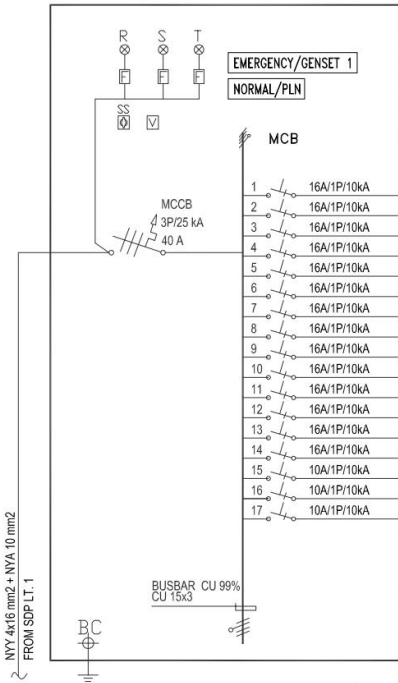

UKURAN KABEL	GROUPING	DAYA (WATT)													
		DL LED 15 W	DL LED + NICAD 15 W	PDI 15 W	TL LED 15 W	TL LED + NICAD 18 W	EF. 200 CFM 50 W	STC 250 W	R	S	T				
NY 3x4 mm2	L.1.A	5	3				1	5	3	1510					
NY 3x4 mm2	L.1.B	10	3				2	9	7		2665				
NY 3x4 mm2	L.1.C	6	2	2			1	5	3					1450	
NY 3x4 mm2	L.1.D	6	2	2			1	5	3	1450					
NY 3x4 mm2	L.1.E			2			1	5	3		1450				
NY 3x4 mm2	L.1.F			2			1	5	3					1450	
NY 3x4 mm2	L.1.G	6	2	2			1	5	3	1450					
NY 3x4 mm2	L.1.H	6					1	5	3		1450				
NY 3x4 mm2	L.1.I	6					1	5	3					1450	
NY 3x4 mm2	L.1.J	4					1	1	1	420					
NY 3x4 mm2	L.1.K						12			9		864			
NY 3x4 mm2	L.1.L						1		1					278	
NY 3x4 mm2	S. ME							5		1250					
NY 3x4 mm2	S.FOCUS							4						1000	
	SPARE														
	SPARE														
		26	2	1	12	11	59	42		6080	6429	5628			
										TOTAL DAYA = 18137	WATT				
										TOTAL DAYA = 34	A				
										TOTAL DAYA = 22671	VA				

WIRING PANEL - LP - LT. 1

SCALE : NTS

KETERANGAN REFERENCE		
NOMOR PROJEK PROJECT NO.		
SINI SANA APARTEMEN		
NO. REVISI	REVISI	TANGGAL
NO. REVISI	REVISI	DATE
KONSULTAN PERENCANA CONSULTANT		
 PT. PADMA BUMI GAREZA		
PERMITS OWNER		
STRUCTURE ENGINEER DESIGNER	STRUCTURE ENGINEER	
NOMOR GAMBAR DRAWING TITLE		
DIGAMBAR DRAW BY	E.H.D	
SKALA SCALE	AS - SHOWN	
TANGGAL DATE	03 OKTOBER 2022	
NO. PROJEK PROJECT NO.	KODE PROJEK PROJECT CODE	KODE GAMBAR DRAWING CODE
		E. 2.01
DEVELOPER/OWNER ISSUED FOR	NO. LEMBAR SHEET NO.	TOTAL LEMBAR SHEET TOTAL
DETAILING ENGINEERING SECTION		

PANEL AC LT. 1
(LP. LT. 1)

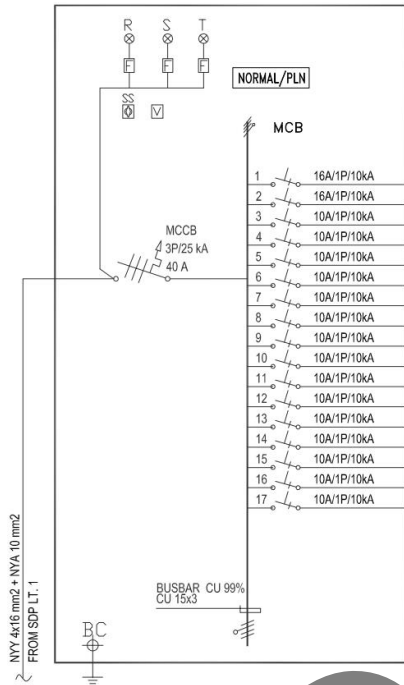

UKURAN KABEL	GROUPING	AC. 0.5 PK 450 W	AC. 1		
			R	S	
1	16A/1P/10kA	NY Y 3x4 mm2	AC.1.A1-A2		
2	16A/1P/10kA	NY Y 3x4 mm2	AC.1.B1-B3		
3	10A/1P/10kA	NY Y 3x4 mm2	AC.1.C		
4	10A/1P/10kA	NY Y 3x4 mm2	AC.1.D	1	
5	10A/1P/10kA	NY Y 3x4 mm2	AC.1.E	1	
6	10A/1P/10kA	NY Y 3x4 mm2	AC.1.F	1	
7	10A/1P/10kA	NY Y 3x4 mm2	AC.1.G	1	
8	10A/1P/10kA	NY Y 3x4 mm2	AC.1.H		
9	10A/1P/10kA	NY Y 3x4 mm2	AC.1.I	1	
10	10A/1P/10kA	NY Y 3x4 mm2	AC.1.J	1	
11	10A/1P/10kA	NY Y 3x4 mm2	AC.1.K	1	
12	10A/1P/10kA	NY Y 3x4 mm2	AC.1.L	1	
13	10A/1P/10kA	NY Y 3x4 mm2	AC.1.M	2	
14	10A/1P/10kA	NY Y 3x4 mm2	AC.1.MR 5	1	
15	10A/1P/10kA	NY Y 3x4 mm2	AC.1.FR 1 & AC.1.FR 2	1	
16	10A/1P/10kA	NY Y 3x4 mm2	AC.1.FR 1 & AC.1.FR 2	1	
17	10A/1P/10kA	NY Y 3x4 mm2	AC.1.FR 1 & AC.1.FR 2	2	
		15	5400	6300	5850
			TOTAL DAYA = 17550	WATT	
			TOTAL DAYA = 33	A	
			TOTAL DAYA = 21938	VA	

WIRING PANEL - AC LT. 1

SCALE : NTS

REVISI		
NO	REVISI	REVISI
NO	REVISI	REVISI
KONSULTAN PERENCANAAN		
CONSULTANT		
 PT. PADMA BUMI GAREZA		
PEMERIKSA		
OWNER		
STRUCTURE ENGINEER		STRUCTURE ENGINEER
KONTROL		
NAMA GAMBAR DRAWING TITLE		
DESAINER DESAIN BY: H. D		
SKALA SCALE: AS - SHOWN		
TANGGAL DATE: 03 OKTOBER 2022		
NO. PROJEK	KODE PROJEK	KODE GAMBAR
PROJECT NO.	PROJECT CODE	DRAWING CODE
		E. 2.01
DEVELOPER/OWNER	NO. LEMBAR	TOTAL LEMBAR
ISSUED FOR	SHEET NO.	SHEET TOTAL
DETAILING		
ENGINEERING SECTION		

SUB DISTRIBUTION PANEL LT. 2
(SDP. LT. 2)

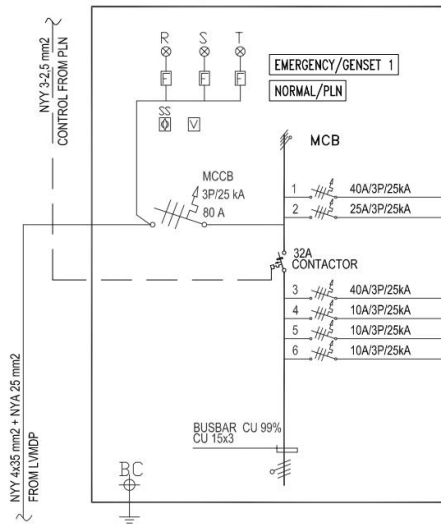

UKURAN KABEL	LOAD	LOAD	TOTAL
			S
1 NY 4x16 mm ² + NYA 10 mm ²	LP - LT. LT. 2	7312	7312
2 NY 4x6 mm ² + NYA 6 mm ²	LP - LT. PENT HOUSE	2520	2520
3 NY 4x16 mm ² + NYA 10 mm ²	PP - AC	21375	7125
4 10A/3P/25kA	SPARE		
5 10A/3P/25kA	SPARE		
6 10A/3P/25kA	SPARE		
			16957
	PLN	2061	VA
	GENSET 1	29486	VA

WIRING PANEL - SDP LT. 2

SCALE : NTS

SAMPLE

REVISION
REFERENCE

NAMA PROJEK
PROJECT NAME

SINI SANA APARTEMEN

NO	REVISI	REVISI	TANGGAL
NO	REVISI	BY	DATE

KONSULTAN PERENCANA
CONSULTANT



PT. PADMA BUMI GAREZA

PERMULAAN
OWNER

STRUCTURE ENGINEER
DESIGNER

STRUCTURE ENGINEER

NAMA GAMBAR
DRAWING TITLE

DITAMBAH
DRAW BY

HE D

SKALA
SCALE

AS - SHOWN

TANGGAL
DATE

03 OKTOBER 2022

NO. PROJEK
PROJECT NO.

KODE PROJEK
PROJECT CODE

KODE GAMBAR
DRAWING CODE

DEVELOPER/OWNER

NO. LEMBAR
SHEET NO.

TOTAL LEMBAR
SHEET TOTAL

DETAILED
ENGINEERING SECTION

E. 2. 01

LIGHTING PANEL LT. 2 PENTHOUSE
(LP. PH)

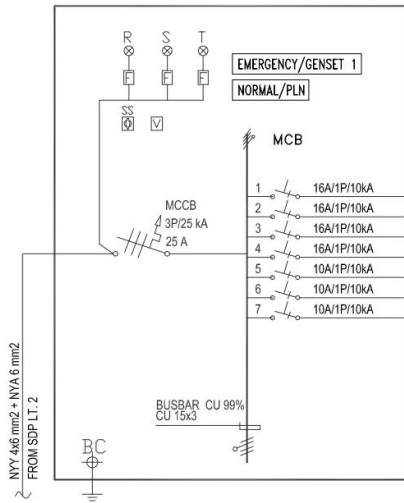

UKURAN KABEL	GROUPING	DL LED 15 W	PDL LED 15 W	WATT	CFM	WTC. 2	DAYA (W)		
							R	S	T
NY 3x4 mm2	LPENTHOUSE 1			1	5	5	1510		
NY 3x4 mm2	LPENTHOUSE 2			1		5		1510	
NY 3x4 mm2	LPENTHOUSE 3			1	1	5			1510
NY 3x4 mm2	LPENTHOUSE 4			1		5	1510		
	SPARE								
	SPARE								
	SPARE								
				20		20	3020	1510	1510
TOTAL DAYA = 6040							WATT		
TOTAL DAYA = 11							A		
TOTAL DAYA = 7550							VA		

WIRING PANEL - LP. PH - LT. 2

SCALE : NTS

SAMPLE

KETERANGAN REFERENSI		
NAMA PROJEK PROJECT NAME		
SINI SANA APARTEMEN		
NO. REVISI	REVISI	TANGGAL
NO. REVISI/UM	BY	DATE
KONSULTAN PERENCANA CONSULTANT		
 PT. PADMA BUMI GAREZA		
PERENCANA OWNER		
STRUCTURE ENGINEER KONSULTOR	STRUCTURE ENGINEER	
NAMA GAMBAR DRAWING TITLE		
DIGAMBAR DRAW BY	E. D	
SKALA SCALE	AS - SHOWN	
TANGGAL DATE	03 OKTOBER 2022	
NO. PROJEK PROJECT NO.	KODE PROJEK PROJECT CODE	KODE GAMBAR DRAWING CODE
		E. 2. 01
DEVELOPER/OWNER	NO. LEMBAR SHEET NO.	TOTAL LEMBAR SHEET TOTAL
DETAILING ENGINEERING SECTION		

SDP LT. ATAP
SDP. ATAP

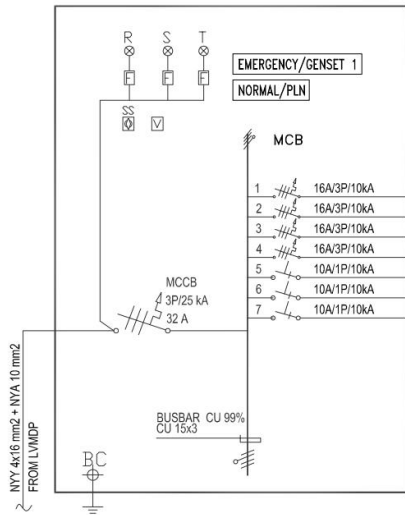

UKURAN KABEL	GROUPING	DAYA (WATT)	VA
NY 4x6 mm2 + NYA 6 mm2	LIFT. 1	2670	2670
NY 4x6 mm2 + NYA 6 mm2	LIFT. 2	2670	2670
NY 4x6 mm2 + NYA 6 mm2	POMPA BOOSTER. RUN	250	250
NY 4x6 mm2 + NYA 6 mm2	POMPA BOOSTER. STAND BY		
	SPARE		
	SPARE		
	SPARE		
		5590	5590
		TOTAL DAYA = 16770	WATT
		TOTAL DAYA = 24	A
		TOTAL DAYA = 20863	VA

WIRING PANEL – SDP ATAP

SCALE : NTS

SAMPLE

KETERANGAN REFERENSI		
NAMA PROJEK PROJECT NAME		
SINI SANA APARTEMEN		
NO. REVISI	REQ.	TANGGAL
NO. REVISI/UM	BY	DATE
KONSULTAN PERENCANA CONSULTANT		
 PT. PADMA BUMI GAREZA		
PEMERINTAH OWNER		
STRUCTURE ENGINEER KONSULTAN	STRUCTURE ENGINEER	
NAMA GAMBAR DRAWING TITLE		
DISUSUN OLEH DRAW BY	E. D	
SKALA SCALE	AS – SHOWN	
TANGGAL DATE	03 OKTOBER 2022	
NO. PROJEK PROJECT NO.	KODE PROJEK PROJECT CODE	KODE GAMBAR DRAWING CODE
		E. 2. 01
DEVELOPER/OWNER	NO. LEMBAR SHEET NO.	TOTAL LEMBAR SHEET TOTAL
DETAILING ENGINEERING SECTION		

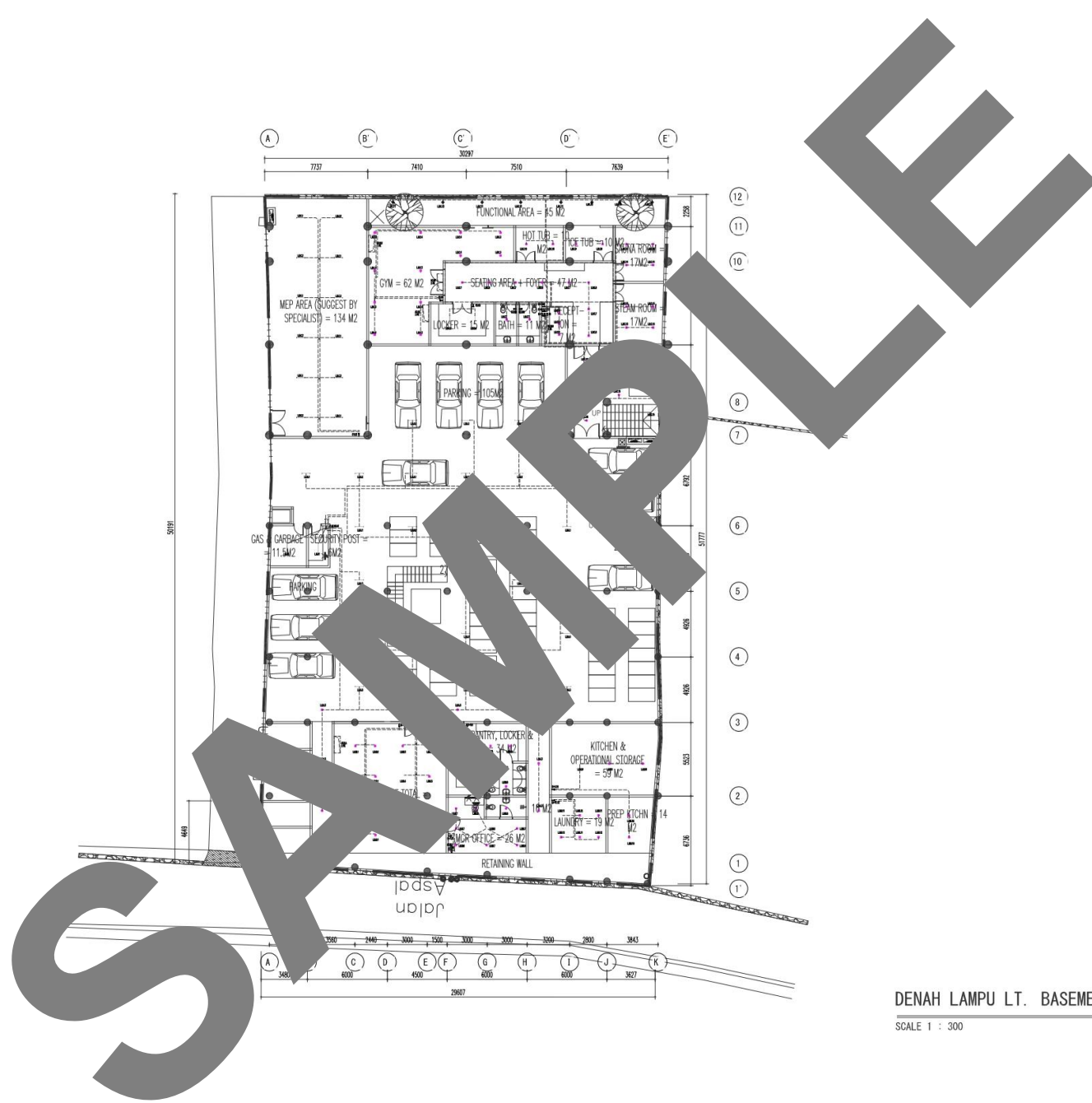

KETERANGAN REFERENSI			
NAMA PROJEK PROJECT NAME			
SINI SANA APARTEMENT			
NO	REVISI	REVISI	TANGGAL
NO	REVISI/DIM	BY	DATE
KONSULTAN PEENCANA CONSULTANT			
 PT. PADMA BUMI GAREZA			
PEMERINTAH TUGAS OWNER			
STRUCTURE ENGINEER KONSULTOR		STRUCTURE ENGINEER	
NAMA GAMBAR DRAWING TITLE			
DISUSUN OLEH DRAW BY		E. D	
SKALA SCALE		AS - SHOWN	
TANGGAL DATE		03 OKTOBER 2022	
NO. PROJEK PROJECT NO.	KODE PROJEK PROJECT CODE	KODE GAMBAR DRAWING CODE	
		E. 2.01	
DEVELOPER/OWNER		NO. LEMBAR SHEET NO.	TOTAL LEMBAR SHEET TOTAL
DETAILING ENGINEERING SECTION			

DENAH LAMPU LT. BASEMENT
SCALE 1 : 300

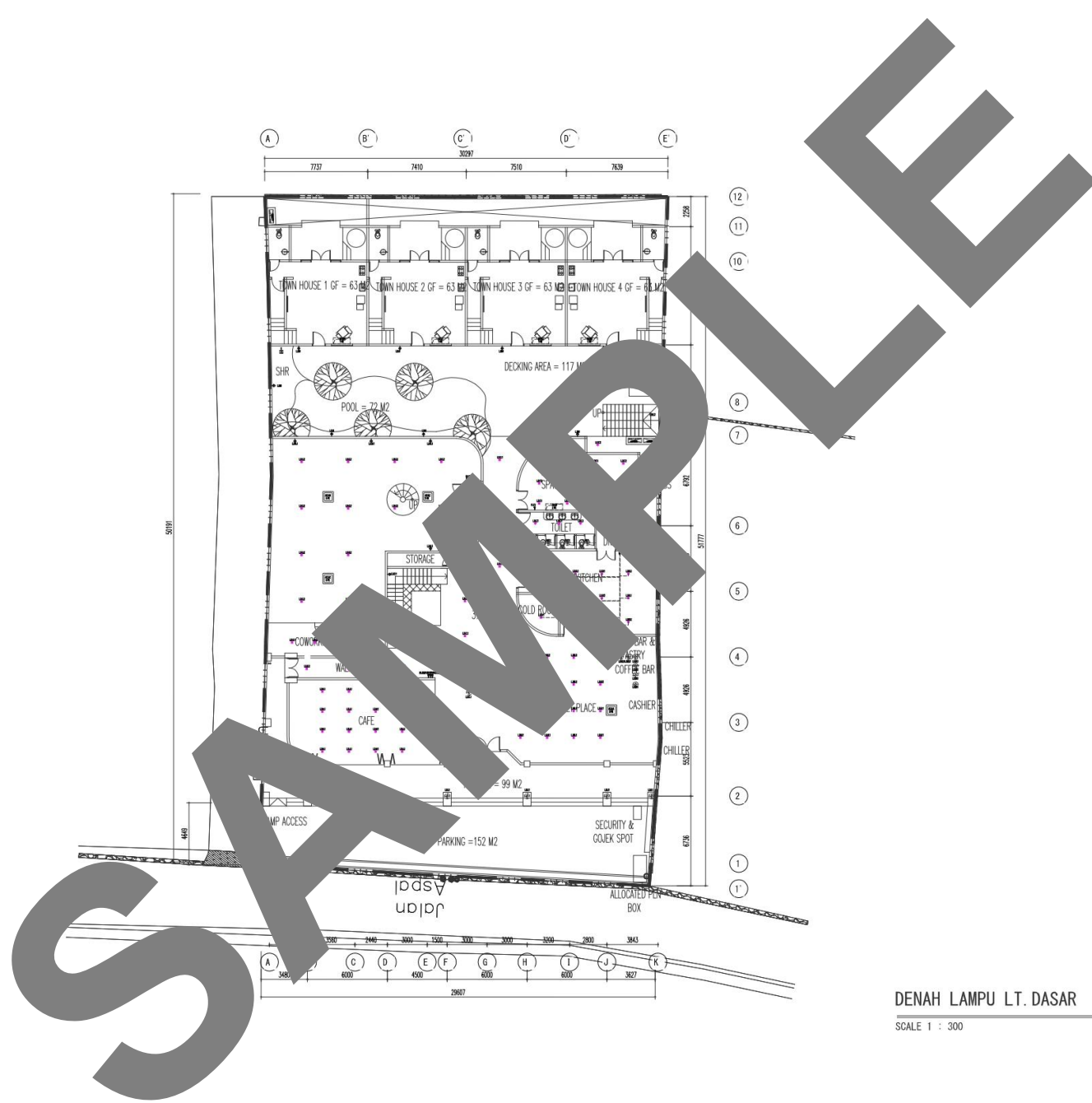

DENAH LAMPU LT. DASAR

SCALE 1 : 300

REVISI/REVISI		
REFERENSI		
NAMA PROJEK PROJECT NAME		
SINI SANA APARTEMEN		
NO	REVISI	REVISI
NO	REVISI	DATE
KONSULTAN PERENCANAAN CONSULTANT		
 PT. PADMA BUMI GAREZA		
PENERBIT/ISSUES		
OWNER		
STRUCTURE ENGINEER	STRUCTURE ENGINEER	
NAMA GAMBAR DRAWING TITLE		
DISAMBAH DRAW BY	E. D	
SKALA SCALE	AS - SHOWN	
TANGGAL DATE	03 OKTOBER 2022	
NO. PROJEK PROJECT NO.	KODE PROJEK PROJECT CODE	KODE GAMBAR DRAWING CODE
		E. 2. 02
DEVELOPER/OWNER	NO. LEMBAR SHEET NO.	TOTAL LEMBAR SHEET TOTAL
DETAILING ENGINEERING SECTION		

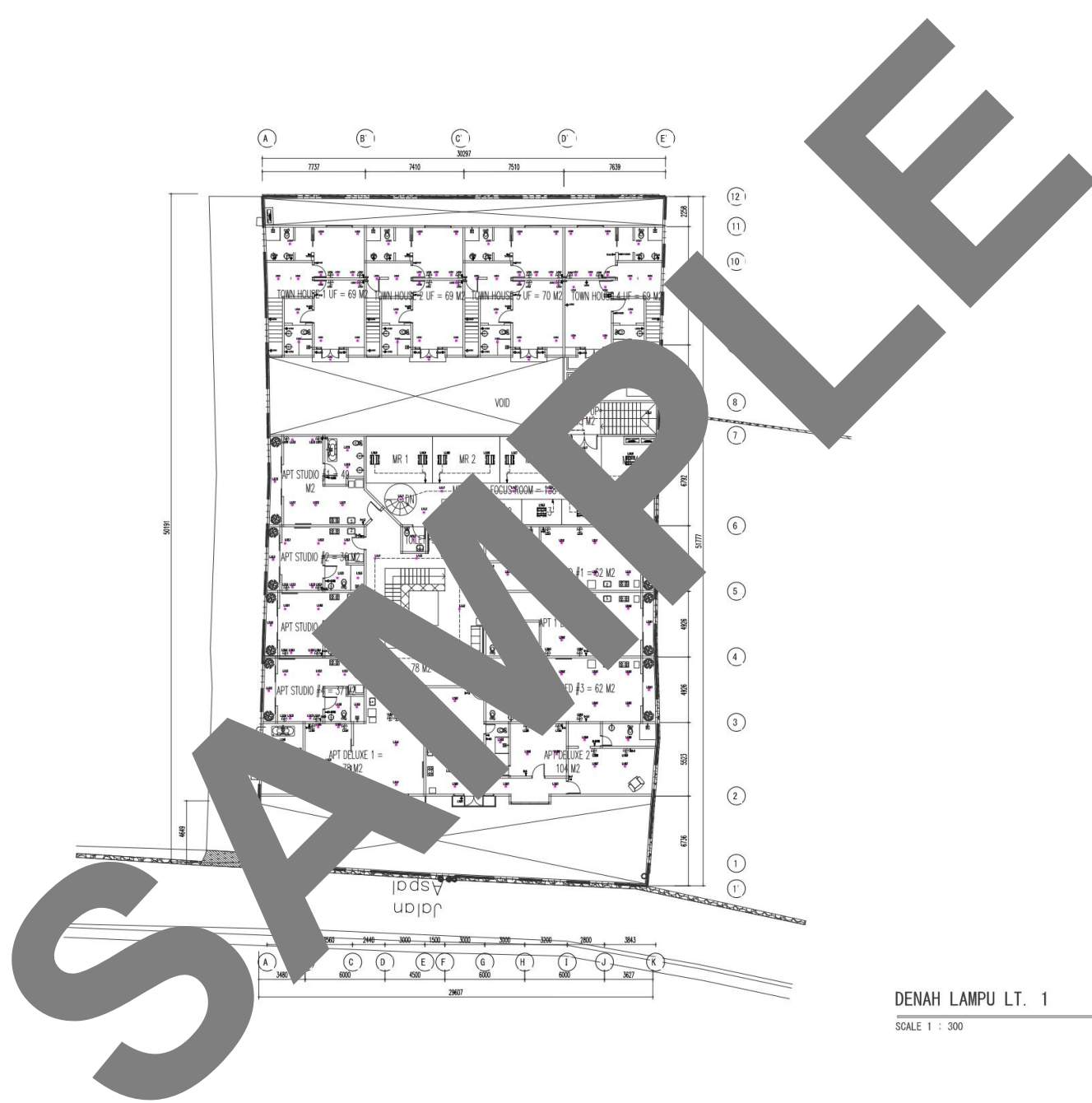

REVISION REFERENSI		
NAMA PROJEK PROJECT NAME		
SINI SANA APARTEMEN		
NO	REVISI	REVISI
NO	REVISI	REVISI
KONSULTAN PEENCANA CONSULTANT		
 PT. PADMA BUMI GAREZA		
PEMERINTAH OWNER		
STRUCTURE ENGINEER	STRUCTURE ENGINEER	
NAMA GAMBAR DRAWING TITLE		
DISENIBAR DRAW BY	EH D	
SKALA SCALE	AS - SHOWN	
TANGGAL DATE	03 OKTOBER 2022	
NO. PROJEK PROJECT NO.	KODE PROJEK PROJECT CODE	KODE GAMBAR DRAWING CODE
		E. 2. 03
DEVELOPER/DOKTER ISSUED FOR	NO. LEMBAR SHEET NO.	TOTAL LEMBAR SHEET TOTAL
DETAILING ENGINEERING SECTION		

DENAH LAMPU LT. 1

SCALE 1 : 300

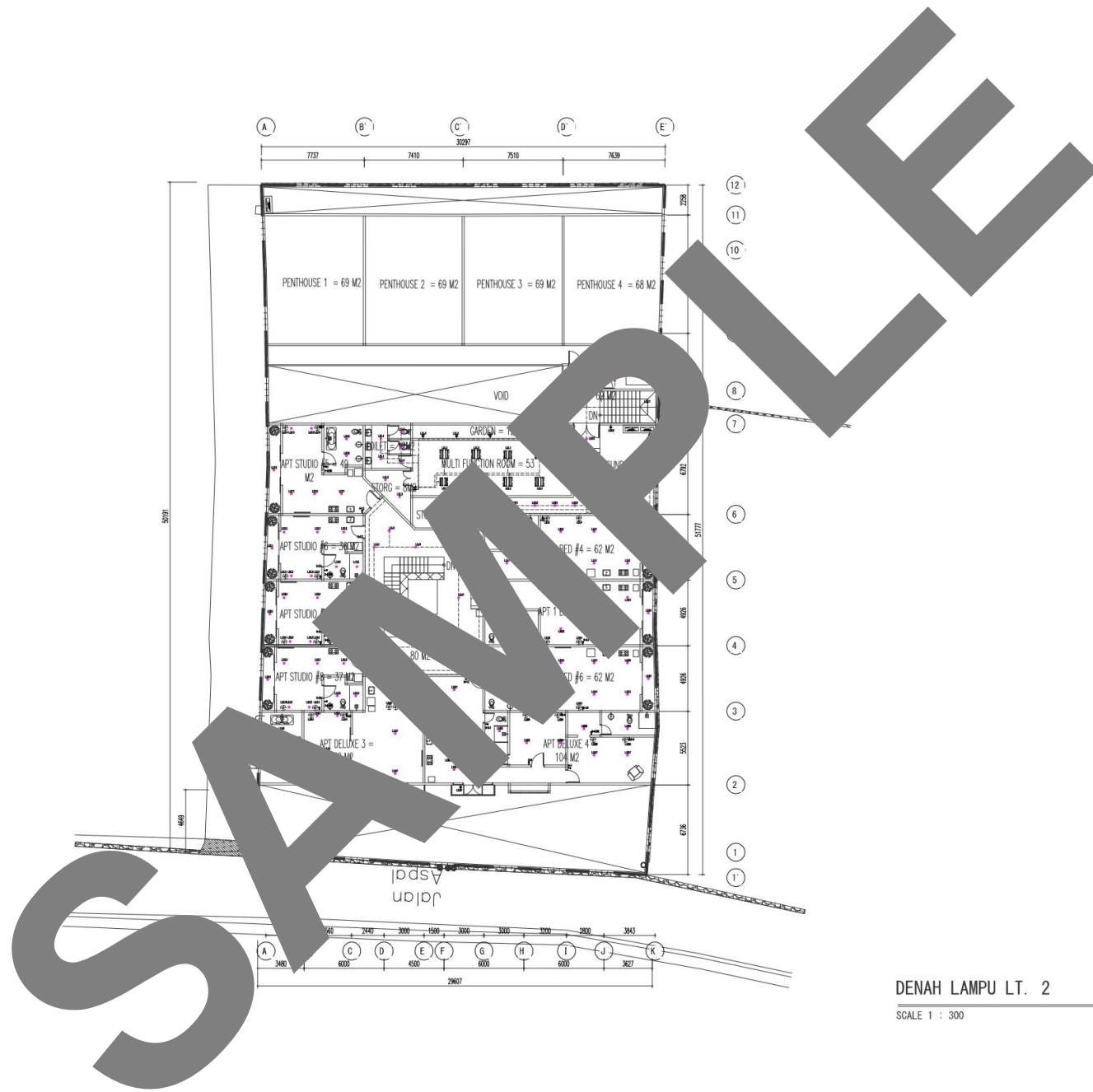

REVISI/REVISI

REFERENSI

NAMA PROJEK

PROJECT NAME

SINI SANA APARTEMEN

NO	REVISI	REVISI	TANGGAL
NO	REVISI	BY	DATE

KONSULTAN PERENCANA

CONSULTANT



PT. PADMA BUMI GAREZA

PEMERINTAH

OWNER

STRUCTURE ENGINEER

CONSULTANT

STRUCTURE ENGINEER

NAMA GAMBAR

DRAWING TITLE

DISAMBAH

BY

SKALA

AS - SHOWN

TANGGAL

03 OKTOBER 2022

DATE

NO. PROJEK

KODE PROJEK

KODE GAMBAR

PROJECT NO.

PROJECT CODE

DRAWING CODE

E. 2. 04

DEVELOPER/OWNER

NO. LEMBAR

TOTAL LEMBAR

ISSUED FOR

SHEET NO.

SHEET TOTAL

DETAILING

ENGINEERING SECTION

DENAH LAMPU LT. 2

SCALE 1 : 300

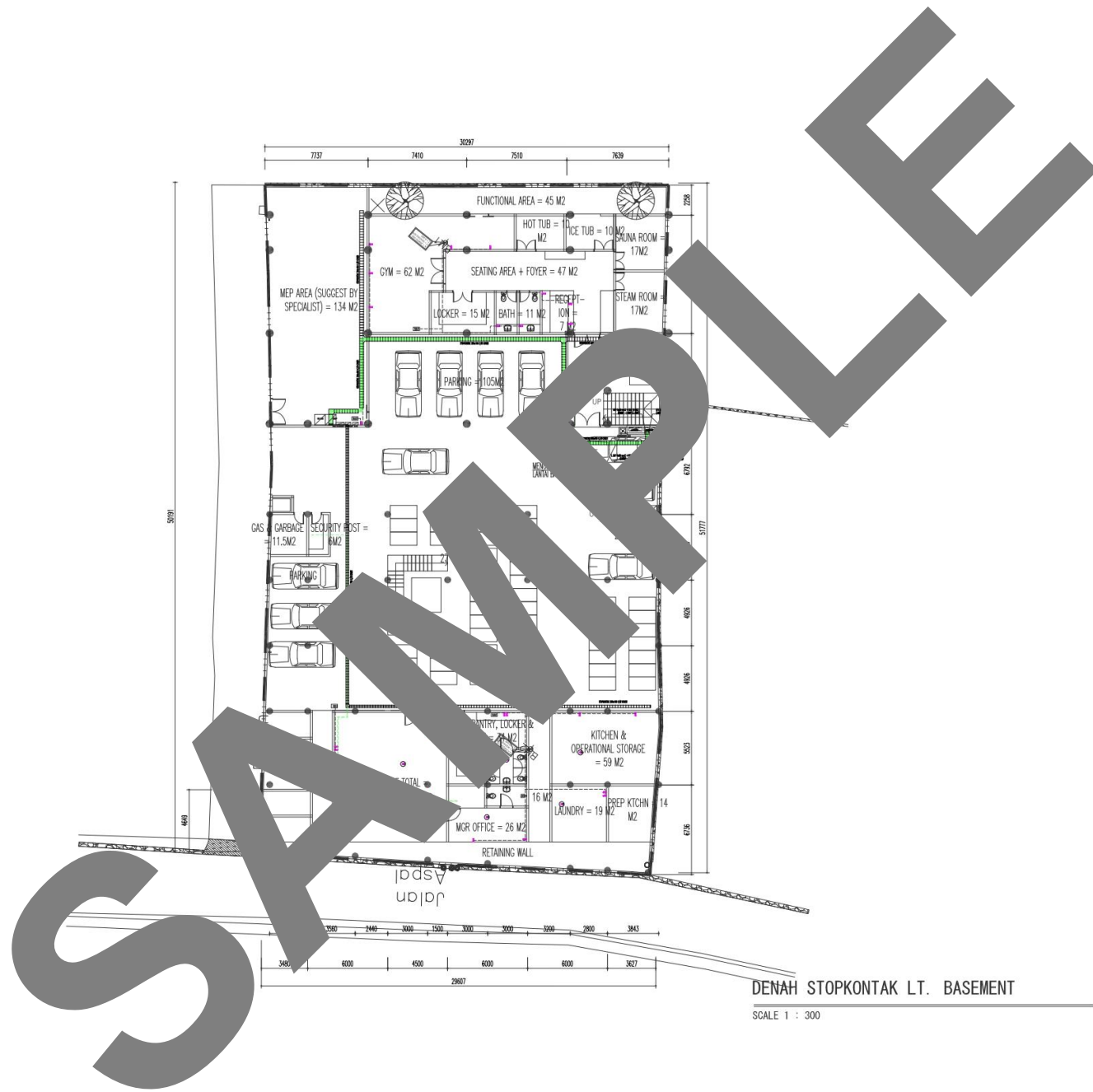

DENAH STOPKONTAK LT. BASEMENT

SCALE 1 : 300

KETERANGAN REFERENSI		
NAMA PROJEK PROJECT NAME		
SINI SANA APARTEMEN		
NO	REVISI	REVISI
NO	REVISI	REVISI
KONSULTAN PEKERJAAN CONSULTANT		
 PT. PADMA BUMI GAREZA		
PEMERINTAH TUGAS OWNER		
STRUCTURE ENGINEER KONSULTAN		STRUCTURE ENGINEER
NAMA GAMBAR DRAWING TITLE		
DISEKUI/DIBAR	E. D	
DIBAR	AS - SHOWN	
SKALA SCALE	AS - SHOWN	
TANGGAL DATE	03 OKTOBER 2022	
NO. PROJEK PROJECT NO.	KODE PROJEK PROJECT CODE	KODE GAMBAR DRAWING CODE
		E. CF. 01
DEVELOPER/OWNER	NO. LEMBAR SHEET NO.	TOTAL LEMBAR SHEET TOTAL
DETAILING ENGINEERING SECTION		

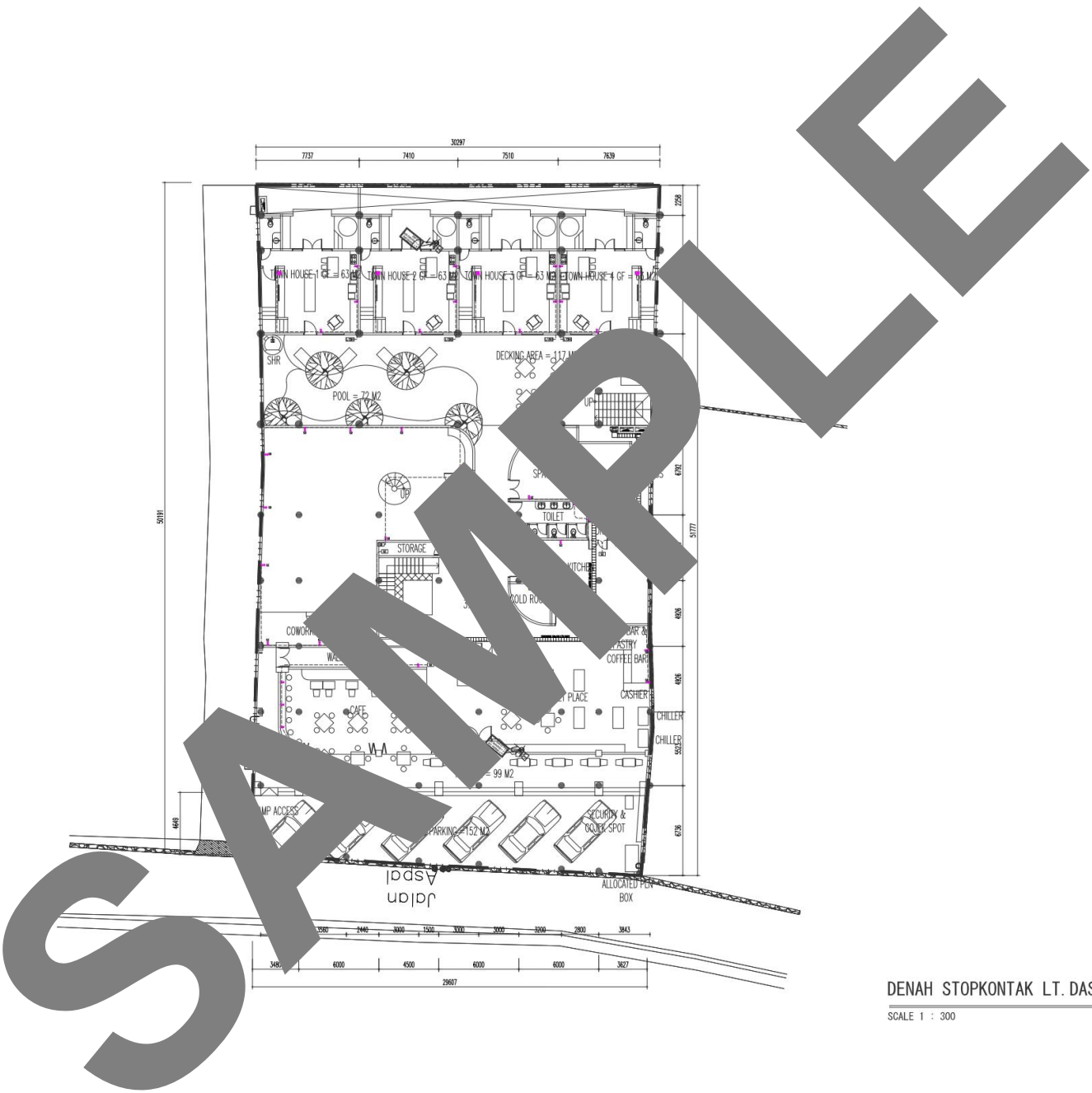

REVISI/REVISI		
REFERENSI		
NAMA PROJEK PROJECT NAME		
SINI SANA APARTEMEN		
NO	REVISI	REVISI
NO	REVISI	REVISI
NO	REVISI	REVISI
NO	REVISI	REVISI
NO	REVISI	REVISI
NO	REVISI	REVISI
NO	REVISI	REVISI
NO	REVISI	REVISI
KONSULTAN PERENCANA CONSULTANT		
 PT. PADMA BUMI GAREZA		
PEMERINTAH/PEMERINTAH		
OWNER		
STRUCTURE ENGINEER	STRUCTURE ENGINEER	
DESIGNER		
NAMA GAMBAR DRAWING TITLE		
DENAH STOPKONTAK		
DISUSUN OLEH DRAWN BY	E. D.	
SKALA SCALE	AS - SHOWN	
TANGGAL DATE	03 OKTOBER 2022	
NO. PROJEK PROJECT NO.	KODE PROJEK PROJECT CODE	KODE GAMBAR DRAWING CODE
		E. CF. 02
DEVELOPER/OWNER	NO. LEMBAR SHEET NO.	TOTAL LEMBAR SHEET TOTAL
DETAILING ENGINEERING SECTION		

DENAH STOPKONTAK LT. DASAR

SCALE 1 : 300

SAMPLE



DENAH STOPKONTAK LT. 1

SCALE 1 : 300

KETERANGAN REFERENCE		
NAMA PROJEK PROJECT NAME		
SINI SANA APARTEMEN		
NO. REVISI	REQ.	TANGGAL
NO. REVISION	BY	DATE
KONSULTAN PEENCANA CONSULTANT		
 PT. PADMA BUMI GAREZA		
PEMERINTAH TUGAS OWNER		
STRUCTURE ENGINEER KONSULTOR	STRUCTURE ENGINEER	
NAMA GAMBAR DRAWING TITLE		
DISENIBAR EH D		
DIBAR AS - SHOWN		
TANGGAL 03 OKTOBER 2022		
NO. PROYEK PROJECT NO.	KODE PROJEK PROJECT CODE	KODE GAMBAR DRAWING CODE
		E. CF. 03
DEVELOPER/DOKTER ISSUED FOR		TOTAL LEMBAR SHEET TOTAL
DETAILING ENGINEERING SECTION		

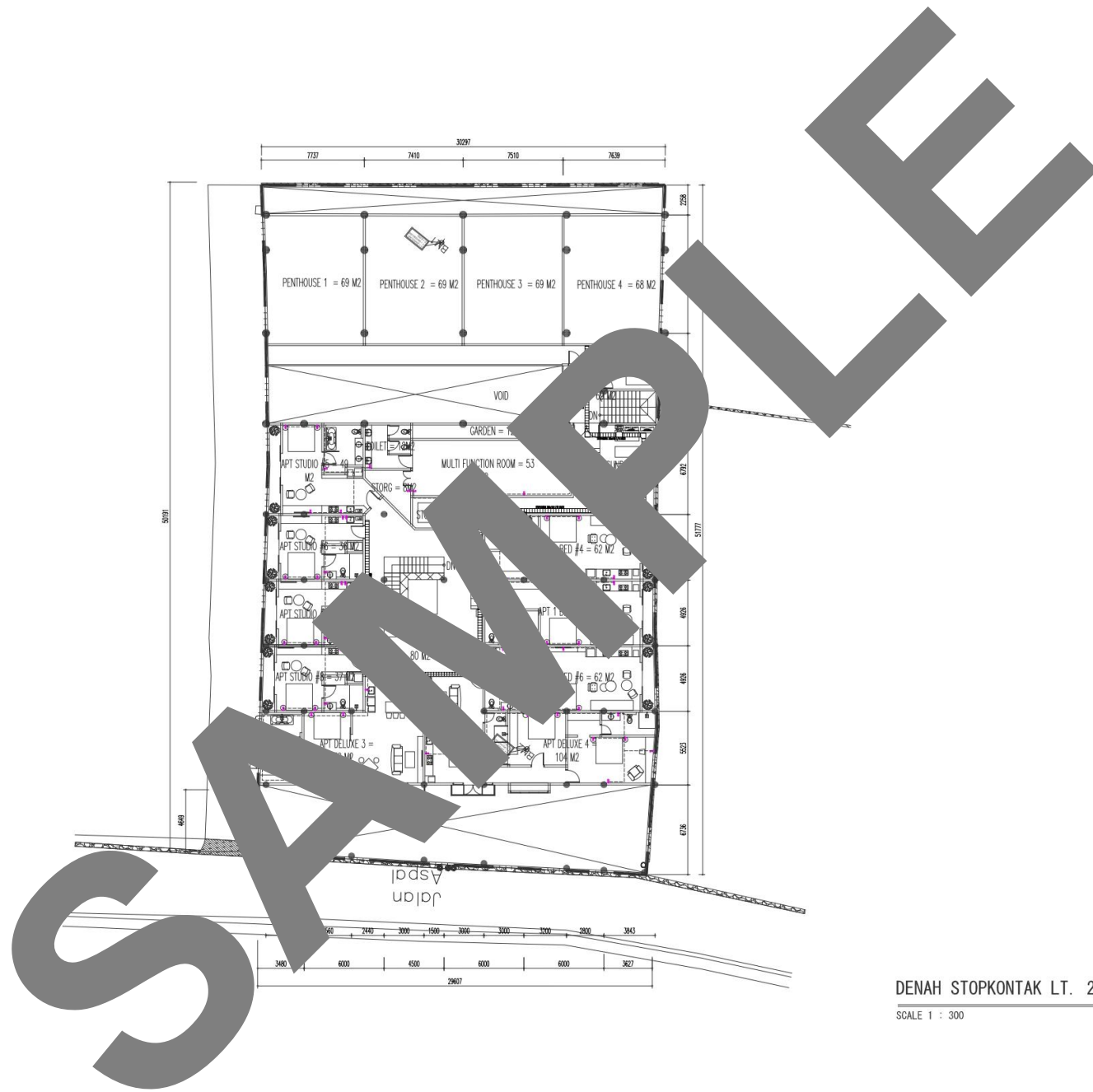

REVISI
REFERENSI

NAMA PROJEK
PROJECT NAME

SINI SANA APARTEMEN

NO	REVISI	REVISI	TANGGAL
NO	REVISI	BY	DATE

KONSULTAN PERENCANA
CONSULTANT



PT. PADMA BUMI GAREZA

PEMERINTAH
OWNER

STRUCTURE ENGINEER
DESIGNER

STRUCTURE ENGINEER

NAMA GAMBAR
DRAWING TITLE

DISENAIN
DRAW BY

E. D

SKALA
SCALE

AS - SHOWN

TANGGAL
DATE

03 OKTOBER 2022

NO. PROJEK
PROJECT NO.

KODE PROJEK
PROJECT CODE

KODE GAMBAR
DRAWING CODE

E. CF. 04

DETAILED DRAWING
ISSUED FOR

NO. LEMBAR
SHEET NO.

TOTAL LEMBAR
SHEET TOTAL

DETAILED DRAWING
ENGINEERING SECTION

DENAH STOPKONTAK LT. 2

SCALE 1 : 300

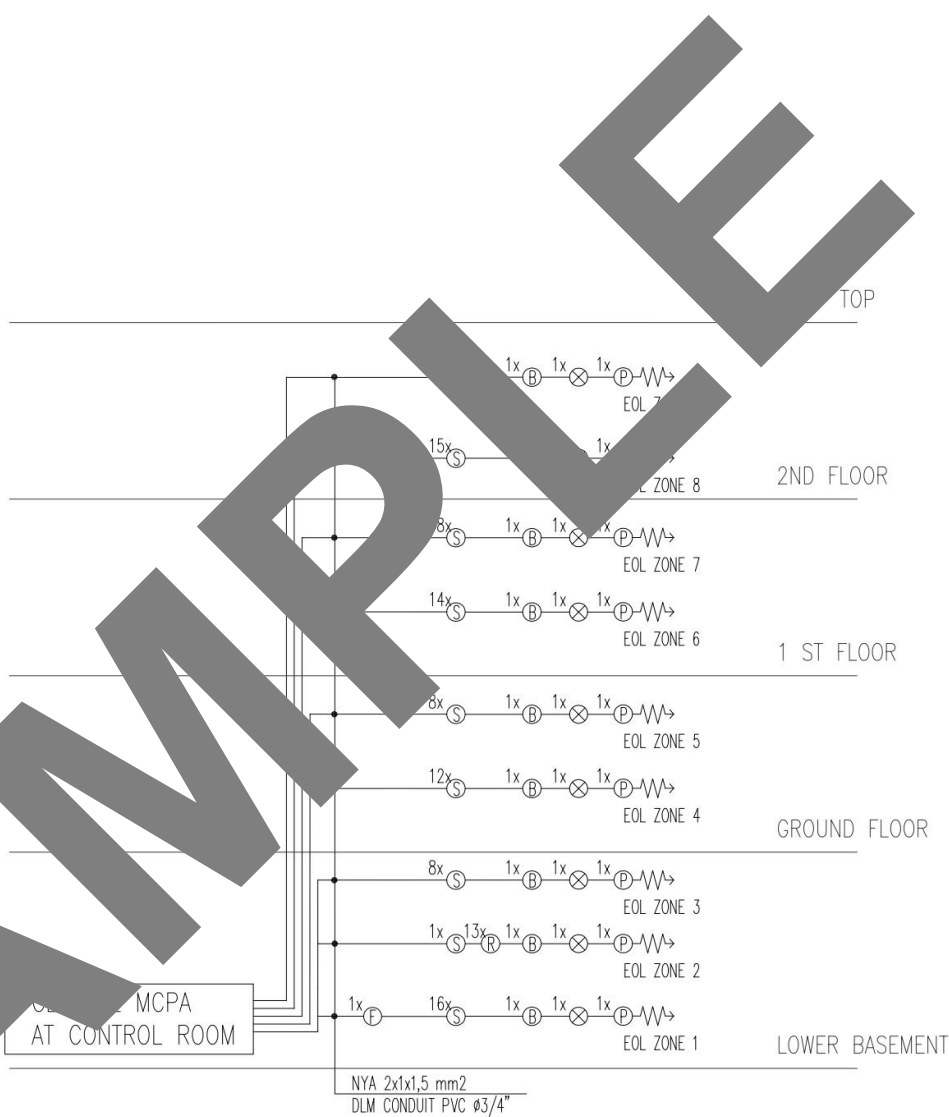
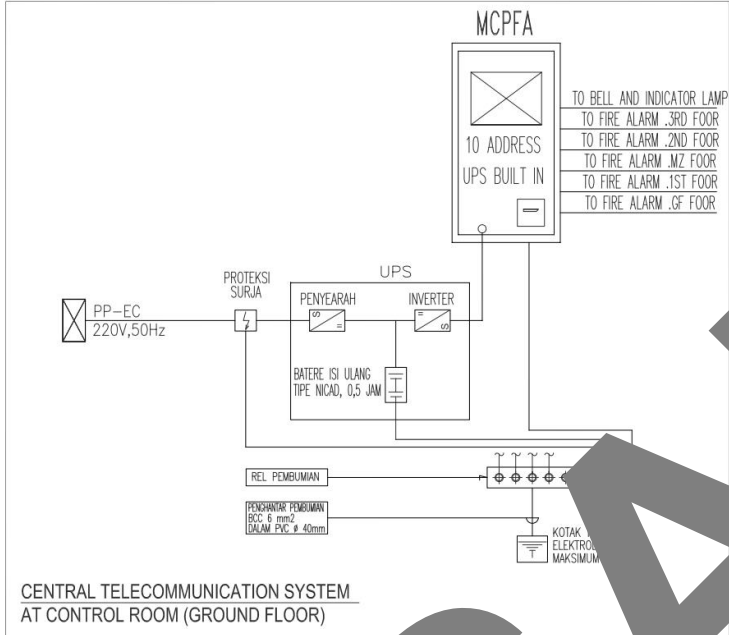

SYMBOLS	REMARKS
Ⓡ	DETEKSI PANAS HEAT DETECTOR + RDR
Ⓣ	DETEKSI PANAS FIXED TEMP. DETECTOR
Ⓢ	DETEKSI ASAP SMOKE DETECTOR
Ⓟ	BEL ALARM ALARM BELL
Ⓟ	TOMBOL TEKAN MANUAL MANUAL PUSH BUTTON
ⓧ	INDIKATOR LAMPU LAMP INDIKATOR
ⓧ	GARIS AKHIR END OF LINE

CATATAN :
- INSTALASI FIRE ALARM
- PENYANGKUTAN NYA 2x1,5 mm²
DALAM HIGH IMPACT CONDUIT ø20mm

NAMA PROJEK
PROJECT NAME
SINI SANA APARTEMEN

NO	REVISI	REVISI	TANGGAL
NO	REVISI/NO	BY	DATE

KONSULTAN PERENCANA
CONSULTANT

PADMA STRUKTUR
PT. PADMA BUMI GAREZA

PEMERINTAH
OWNER

STRUCTURE ENGINEER	STRUCTURE ENGINEER

NAMA ORANG
DRAWING TITLE

DITAMBAH
DRAW BY
SKALA
SCALE: AS - SHOWN
TANGGAL
DATE: 03 OKTOBER 2022

NO. PROJEK	KODE PROJEK	KODE GAMBAR
PROJECT NO.	PROJECT CODE	DRAWING CODE
DEVELOPER/OWNER	NO. LEMBAR	TOTAL LEMBAR
ISSUED FOR	SHEET NO.	SHEET TOTAL
DETAILING ENGINEERING SECTION		

DIAGRAM SISTEM FIRE ALARM

SCALE : NTS

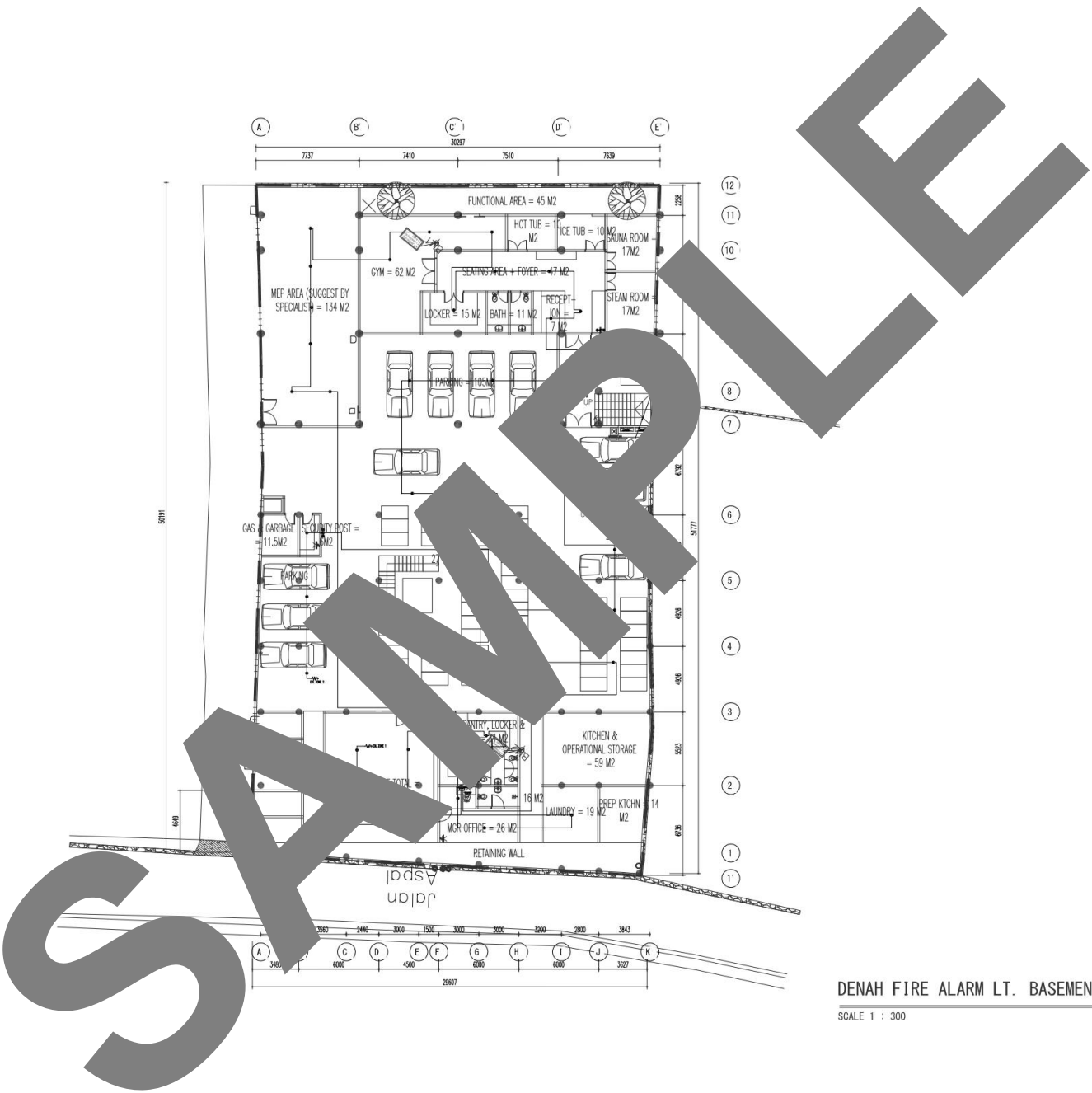

SYMBOLS	REMARKS
(R)	DETEKSI PANAS HEAT DETECTOR + RDR
(F)	DETEKSI PANAS FIXED TEMP. DETECTOR
(S)	DETEKSI ASAP SMOKE DETECTOR
(B)	BEL ALARM ALARM BELL
(P)	TOMBOL TEKAN MANUAL MANUAL PUSH BUTTON
(X)	INDIKATOR LAMPU LAMP INDIKATOR
---	GARIS AKHIR END OF LINE

CATATAN :
 - INSTALASI FIRE ALARM
 DENGAN KABEL NIK 2x1.5 mm²
 DALAM HIGH IMPACT CONDUIT #20mm

NAMA PROJEK
 PROJECT NAME
SINI SANA APARTEMEN

NO	REVISI	REVISI	TANGGAL
NO	REVISI/NO	BY	DATE

KONSULTAN PEKERJAAN
 CONSULTANT

PADMA STRUKTUR
 PT. PADMA BUMI GAREZA

PEMERINTAH TUGAS
 OWNER

STRUCTURE ENGINEER	STRUCTURE ENGINEER

NAMA CORBAK
 DRAWING TITLE

DITAMBAH
 DEAR BY: H. D
 SKALA: AS - SHOWN
 SCALE: 03 OKTOBER 2022

DENAH FIRE ALARM LT. BASEMENT

SCALE 1 : 300

NO. PROJEK	KODE PROJEK	KODE GAMBAR
PROJECT NAME	PROJECT CODE	DRAWING CODE
		E. 2.01
DEVELOPER/AN ORDER	NO. LEMBAR	TOTAL LEMBAR
ISSUED FOR	SHEET NO.	SHEET TOTAL
DETAILING ENGINEERING SECTION		

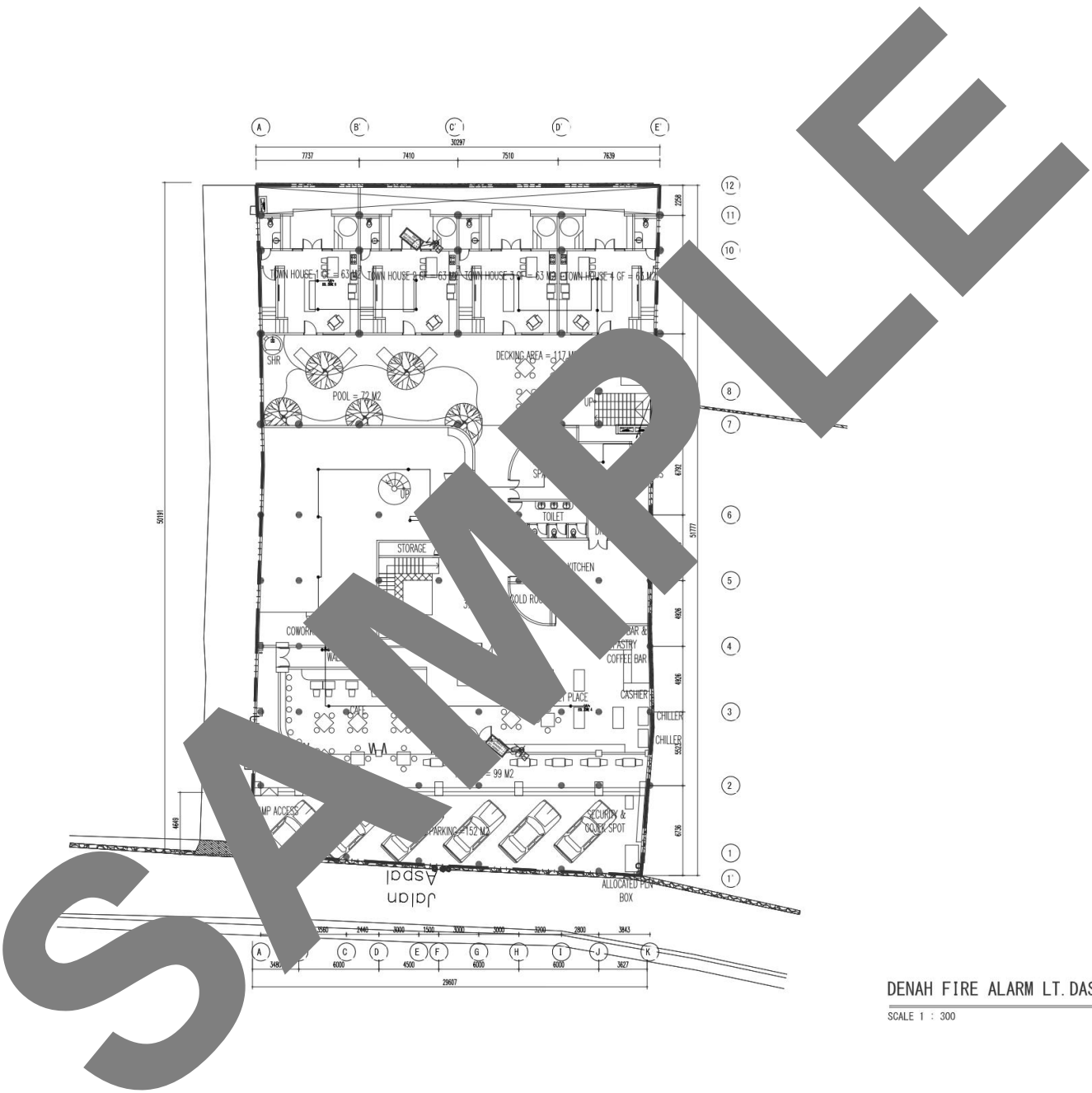

SYMBOLS	REMARKS
Ⓡ	DETEKSI PANAS HEAT DETECTOR + RDR
Ⓣ	DETEKSI PANAS FIXED TEMP. DETECTOR
Ⓢ	DETEKSI ASAP SMOKE DETECTOR
Ⓟ	BEL ALARM ALARM BELL
Ⓟ	TOMBOL TEKAN MANUAL MANUAL PUSH BUTTON
⊗	INDIKATOR LAMPU LAMP INDIKATOR
—	GARIS AKHIR END OF LINE

CATATAN :
 - INSTALASI FIRE ALARM
 DENGAN KABEL NIK 2x1.5 mm²
 DALAM HIGH IMPACT CONDUIT #20mm

NAMA PROJEK
 PROJECT NAME

 SINI SANA APARTEMEN

NO	REVISI	REVISI	TANGGAL
NO	REVISI	BY	DATE

KONSULTAN PERENCANA
 CONSULTANT



PEMERINTAH TUGAS
 OWNER

STRUCTURE ENGINEER	STRUCTURE ENGINEER

NAMA CADANGAN
 DRAWING TITLE

DISUSUN OLEH DRAWN BY	HE D
SKALA SCALE	AS - SHOWN
TANGGAL DATE	03 OKTOBER 2022

NO. PROYEK	KODE PROJEK	KODE GAMBAR
PROJECT NAME	PROJECT CODE	DRAWING CODE
		E. 2. 02
DEVELOPER/AN UNITS	NO LEMBAR	TOTAL LEMBAR
ISSUED FOR	SHEET NO	SHEET TOTAL
DETAILING ENGINEERING SECTION		

DENAH FIRE ALARM LT. DASAR

SCALE 1 : 300

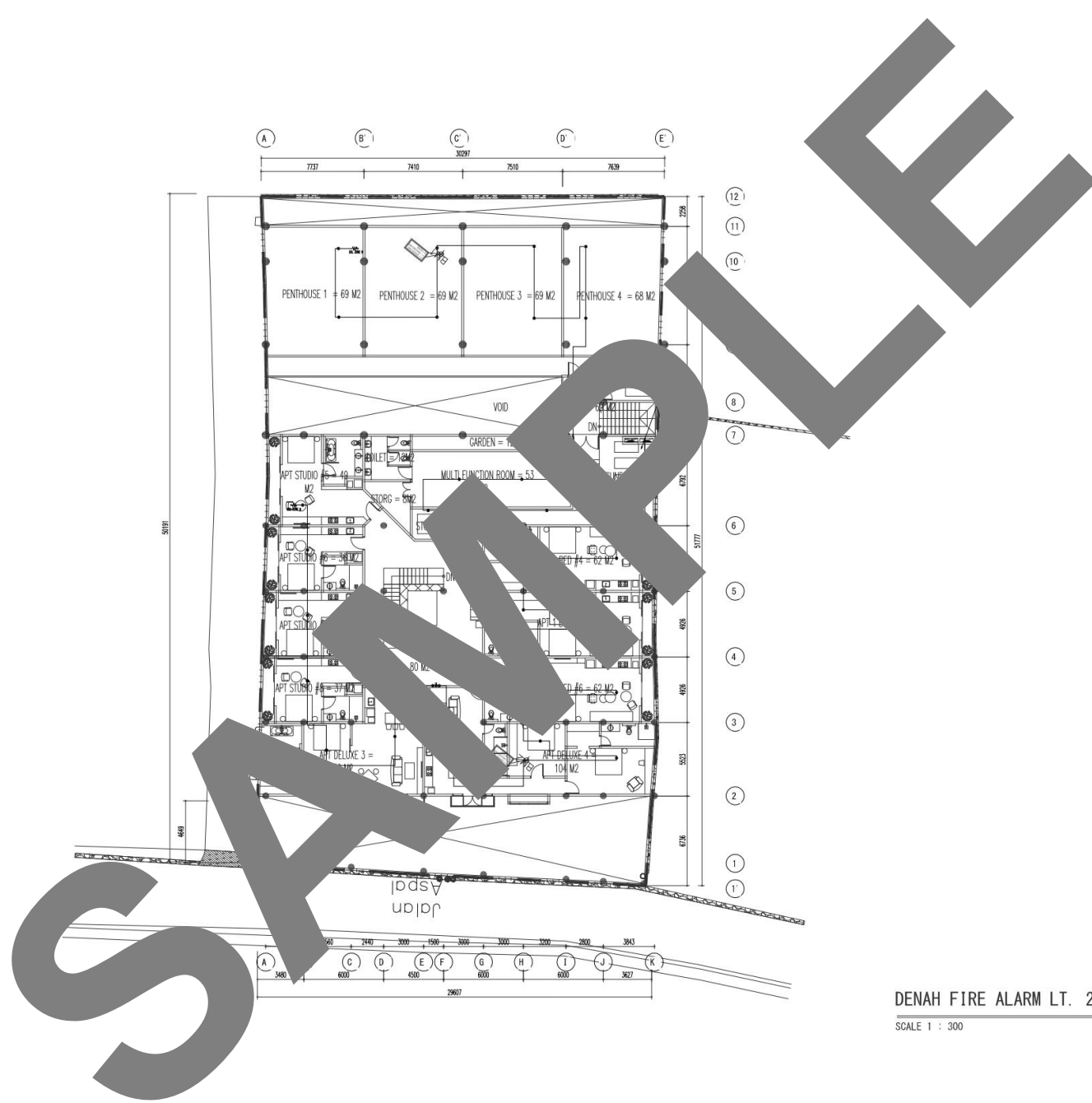

SYMBOLS	REMARKS
Ⓡ	DETEKSI PANAS HEAT DETECTOR + RDR
Ⓣ	DETEKSI PANAS FIXED TEMP. DETECTOR
Ⓢ	DETEKSI ASAP SMOKE DETECTOR
Ⓟ	BEL ALARM ALARM BELL
Ⓟ	TOMBOL TEKAN MANUAL MANUAL PUSH BUTTON
⊗	INDIKATOR LAMPU LAMP INDIKATOR
—	GARIS AKHIR END OF LINE

CATATAN :
 - INSTALASI FIRE ALARM
 PENYUNTAH KABEL NIK 2x1.5 mm²
 DALAM HIGH IMPACT CONDUIT #20mm

NAMA PROJEK
 PROJECT NAME
 SINI SANA APARTEMEN

NO	REVISI	REVISI	TANGGAL
NO	REVISI	BY	DATE

KONSULTAN PERENCANA
 CONSULTANT



PT. PADMA BUMI GAREZA

PEMERINTAH TUGAS
 OWNER

STRUCTURE ENGINEER
 KONSULTAN

STRUCTURE ENGINEER

NAMA GAMBAR
 DRAWING TITLE

DISENIAWAI
 DESAIN BY: H. D.
 SKALA
 SCALE: AS - SHOWN
 TANGGAL
 DATE: 03 OKTOBER 2022

NO. PROYEK	KODE PROJEK	KODE GAMBAR
PROJECT NAME	PROJECT CODE	DRAWING CODE
		E. 2. 04
DEVELOPER/OWNER	NO. LEMBAR	TOTAL LEMBAR
ISSUED FOR	SHEET NO.	SHEET TOTAL
DETAILING ENGINEERING SECTION		

DENAH FIRE ALARM LT. 2

SCALE 1 : 300

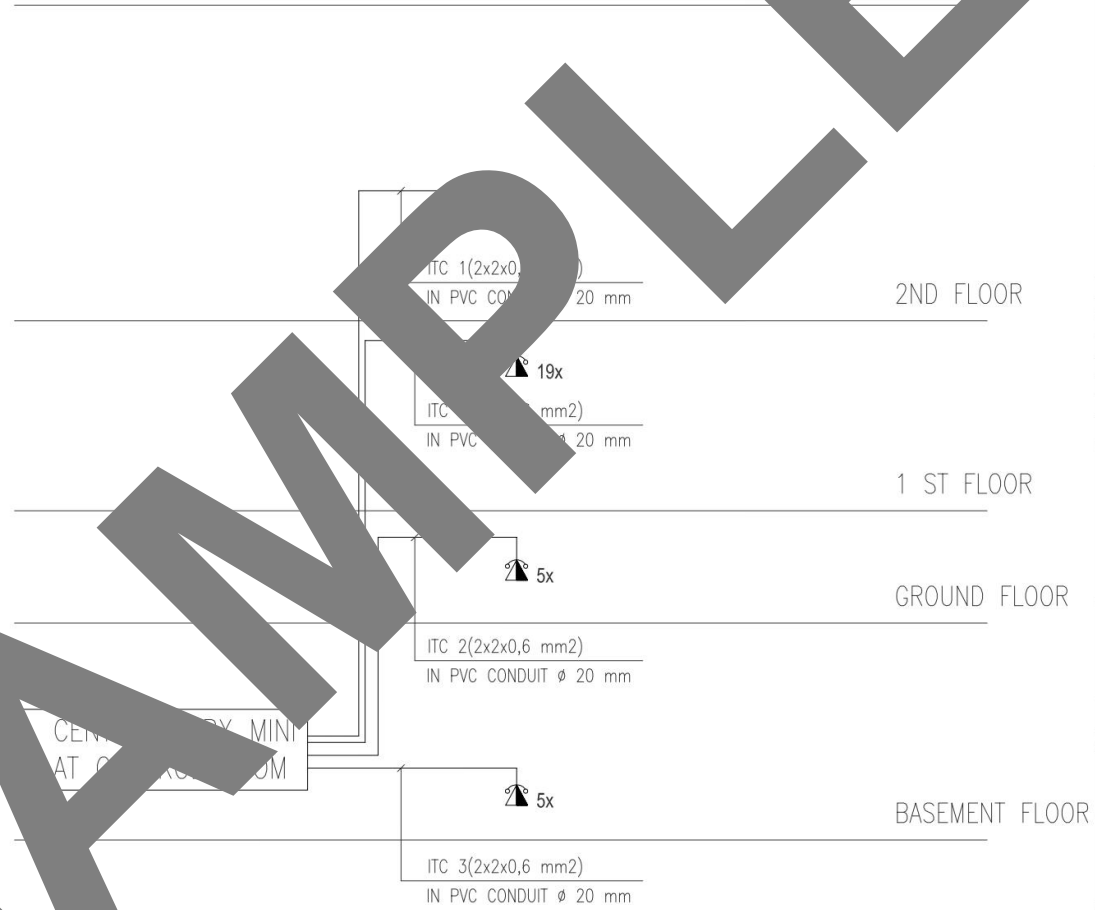
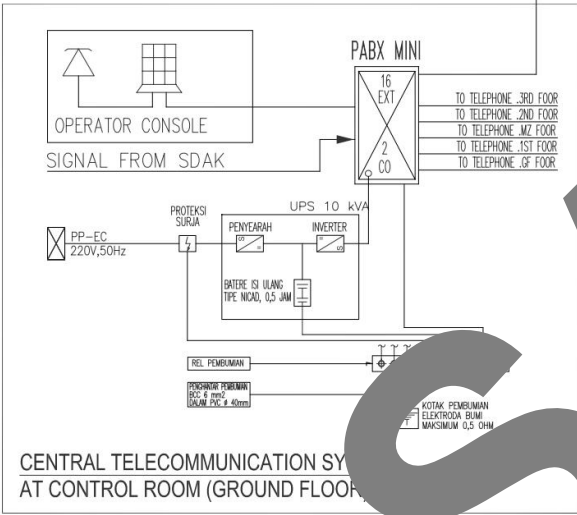
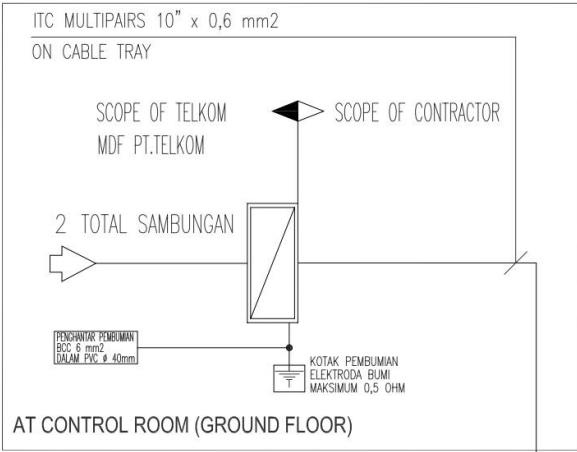

DIAGRAM SISTEM TELEPHONE
SCALE : NTS

SYMBOLS	REMARKS
	OUTLET TELEFON LANGSUNG (RJ11) DIRECT TELEPHONE OUTLET (RJ11)
	OUTLET TELEFON EXTENSION (RJ11) EXTENSION TELEPHONE OUTLET (RJ11)
	PRIVATE AUTOMATIC BRANCH EXCHANGE PRIVATE AUTOMATIC BRANCH EXCHANGE

CATANAN :
- INSTALASI TELEFON MENGGUNAKAN KABEL ITC 2x2x0,6 mm
(KABEL TELEFON) DALAM HIGH IMPACT CONDUIT ø20mm

NO. PROJEK
PROJECT NAME

SINI SANA APARTEMEN

NO	REVISI	REVISI	TANGGAL
NO	REVISI/NO	BY	DATE

KONSULTAN PERENCANA
CONSULTANT



PERENCANA
OWNER

STRUCTURE ENGINEER	CONSULTOR	STRUCTURE ENGINEER

NO. GAMBAR
DRAWING TITLE

DISUSUN OLEH
DIBARAH OLEH

SKALA
SCALE

TANGGAL
DATE

03 OKTOBER 2022

NO. PROJEK	KODE PROJEK	KODE GAMBAR
PROJECT NAME	PROJECT CODE	DRAWING CODE

DEVELOPER/OWNER	NO. LEMBAR	TOTAL LEMBAR
ISSUED FOR	SHEET NO.	SHEET TOTAL

DETAILING
ENGINEERING SECTION

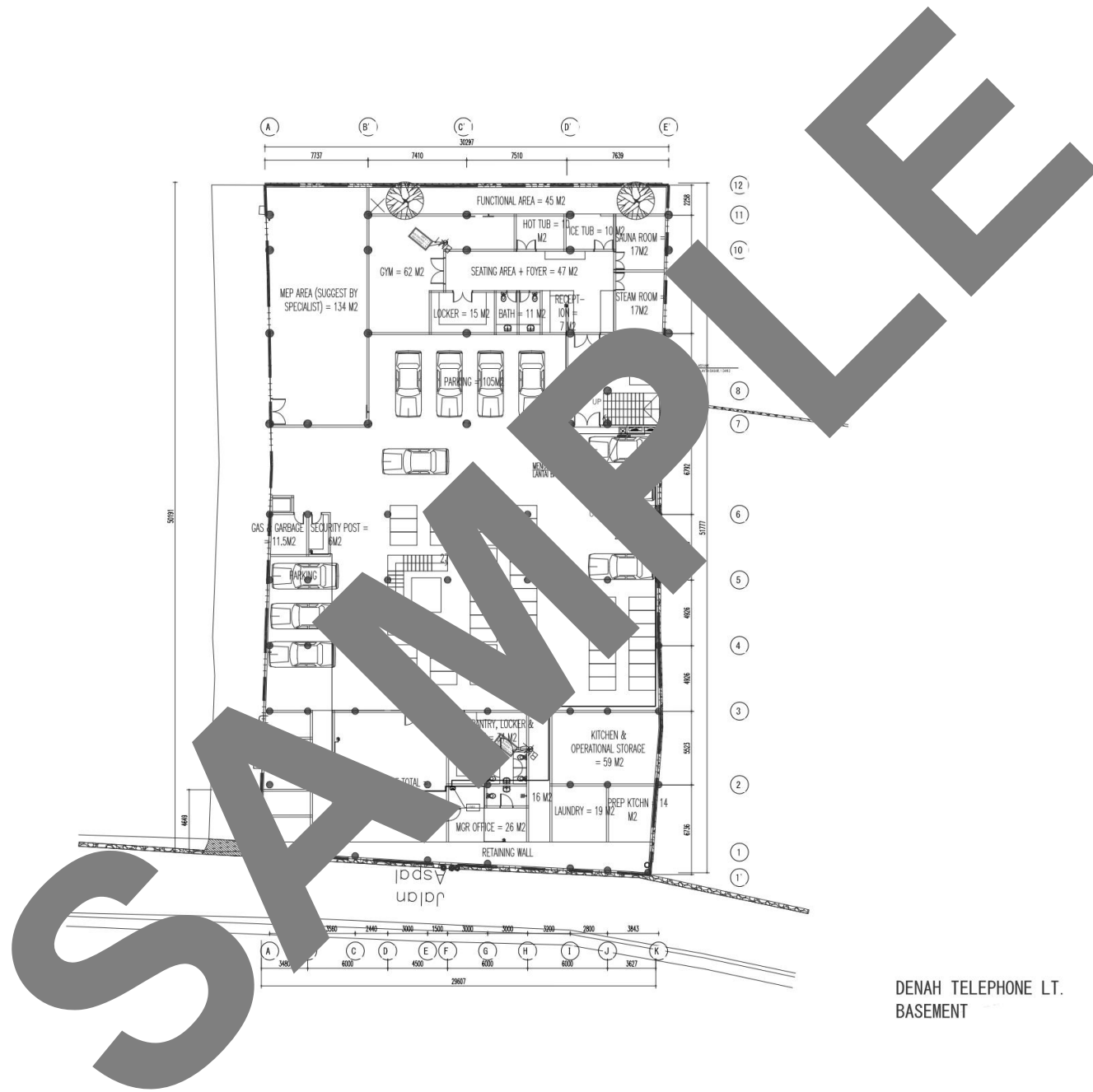

SYMBOLS	REMARKS
	OUTLET TELEFON LANGSUNG (R111) DIRECT TELEPHONE OUTLET (R111)
	OUTLET TELEFON EXTENSION (R111) EXTENSION TELEPHONE OUTLET (R111)
	PRIVATE AUTOMATIC BRANCH EXCHANGE PRIVATE AUTOMATIC BRANCH EXCHANGE

CATANAN :
 - INSTALASI TELEFON MENGGUNAKAN KABEL (TC 2x2x0,6 mm (KABEL TELEFON) DALAM HIGH IMPACT CONDUIT Ø20mm

NAMA PROJEK
 PROJECT NAME
SINI SANA APARTEMEN

NO	REVISI	REVISI	TANGGAL
NO	REVISI/NO	BY	DATE

KONSULTAN PERENCANA
 CONSULTANT

PADMA STRUKTUR
 PT. PADMA BUMI GAREZA

PERENCANA TUGAS
 OWNER

STRUCTURE ENGINEER	STRUCTURE ENGINEER

NAMA GAMBAR
 DRAWING TITLE

DITAMBAH
 DEKOR BY: H. D.
 SKALA
 SCALE: AS - SHOWN
 TANGGAL
 DATE: 03 OKTOBER 2022

NO. PROYEK	KODE PROJEK	KODE GAMBAR
PROJECT NO.	PROJECT CODE	DRAWING CODE
		E. 2.01
DEVELOPER/OWNER	NO. LEMBAR	TOTAL LEMBAR
ISSUED FOR	SHEET NO.	SHEET TOTAL
DETAILING ENGINEERING SECTION		

DENAH TELEPHONE LT.
 BASEMENT

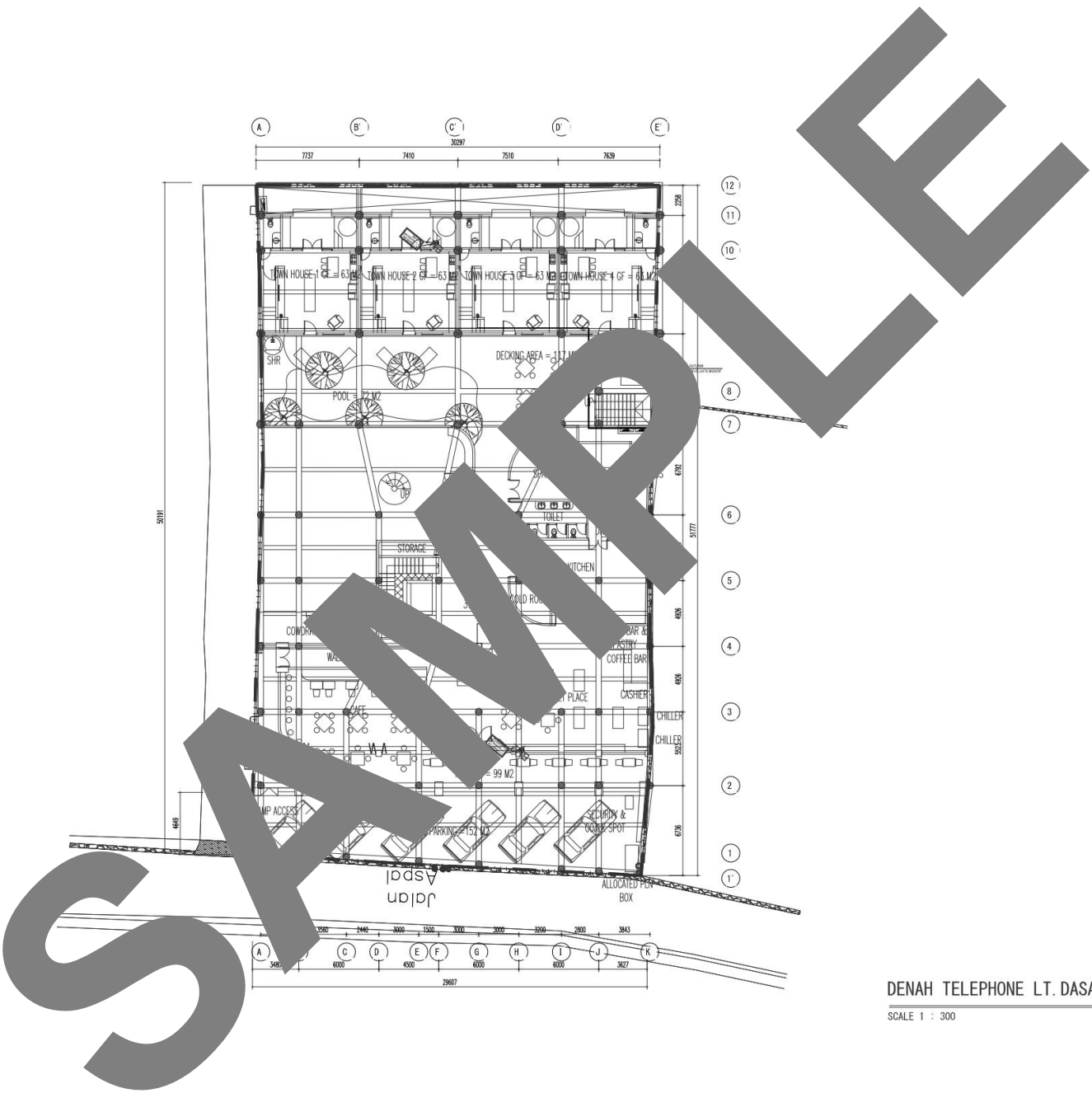

SYMBOLS	REMARKS
	OUTLET TELEFON LANGSUNG (RT11) DIRECT TELEPHONE OUTLET (RT11)
	OUTLET TELEFON EXTENSION (RT11) EXTENSION TELEPHONE OUTLET (RT11)
	PRIVATE AUTOMATIC BRANCH EXCHANGE PRIVATE AUTOMATIC BRANCH EXCHANGE

CATANAN :
 - INSTALASI TELEFON MENGGUNAKAN KABEL (TC 2x2x0,6 mm (KABEL TELEFON) DALAM HIGH IMPACT CONDUIT Ø20mm

NAMA PROJEK
 PROJECT NAME
SINI SANA APARTEMEN

NO	REVISI	REVISI	TANGGAL
NO	REVISI/NO	BY	DATE

KONSULTAN PERENCANA
 CONSULTANT



PERENCANA TUGAS
 OWNER

STRUCTURE ENGINEER
 KONSULTOR

NAMA GAMBAR
 DRAWING TITLE

DITAMBAH
 DESAIN BY: H. D.
 SKALA
 SCALE: AS - SHOWN
 TANGGAL
 DATE: 03 OKTOBER 2022

DENAH TELEFONE LT. DASAR

SCALE 1 : 300

NO. PROJEK	KODE PROJEK	KODE GAMBAR
PROJECT NO.	PROJECT CODE	DRAWING CODE
		E. 2. 02
DEVELOPER/AN ORDER	NO. LEMBAR	TOTAL LEMBAR
ISSUED FOR	SHEET NO.	SHEET TOTAL
DETAILING	ENGINEERING	SECTION

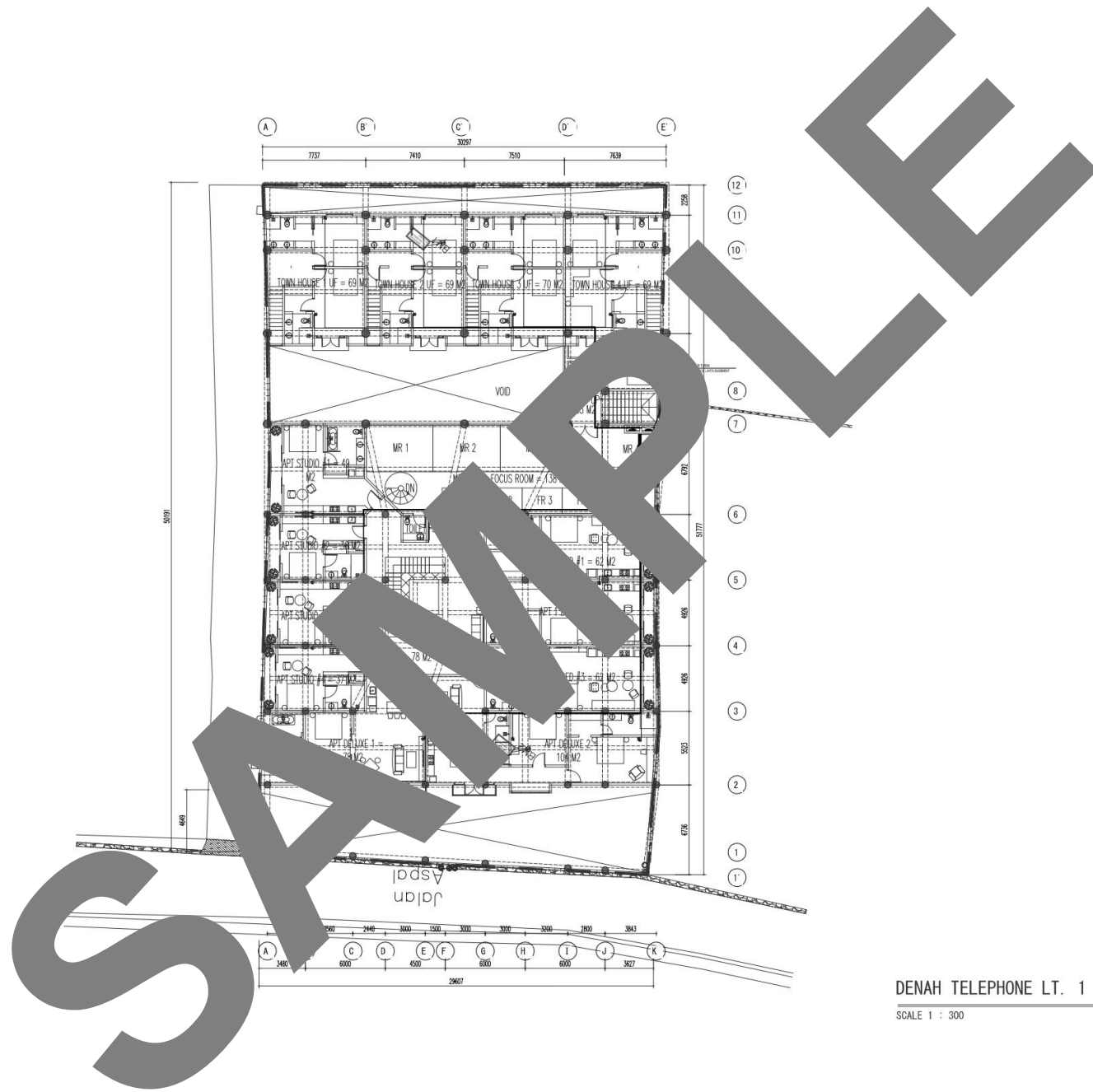

SYMBOLS	REMARKS
	OUTLET TELEFON LANGSUNG (RJT1) DIRECT TELEPHONE OUTLET (RJT1)
	OUTLET TELEFON EXTENSION (RJT1) EXTENSION TELEPHONE OUTLET (RJT1)
	PRIVATE AUTOMATIC BRANCH EXCHANGE PRIVATE AUTOMATIC BRANCH EXCHANGE

CATANAN :
 - INSTALASI TELEFON MENGGUNAKAN KABEL (TC 2x0.6 mm
 (KABEL TELEFON) DALAM HIGH IMPACT CONDUIT Ø20mm

NAMA PROJEK
 PROJECT NAME

SINI SANA APARTEMEN

NO	REVISI	REVISI	TANGGAL
NO	REVISI	BY	DATE

KONSULTAN PERENCANA
 CONSULTANT



PEMERINTAH TUGAS
 OWNER

STRUCTURE ENGINEER
 KONSULTOR

NAMA CONTOH
 DRAWING TITLE

DITAMBAH
 DEKOR BY : H. D.
 SKALA
 SCALE : AS - SHOWN
 TANGGAL
 DATE : 03 OKTOBER 2022

NO. PROJEK	KODE PROJEK	KODE GAMBAR
PROJECT NO.	PROJECT CODE	DRAWING CODE
		E. 2. 03
DEVELOPER/OWNER	NO. LEMBAR	TOTAL LEMBAR
ISSUED FOR	SHEET NO.	SHEET TOTAL
DETAILING	ENGINEERING	SECTION

DENAH TELEPHONE LT. 1

SCALE 1 : 300

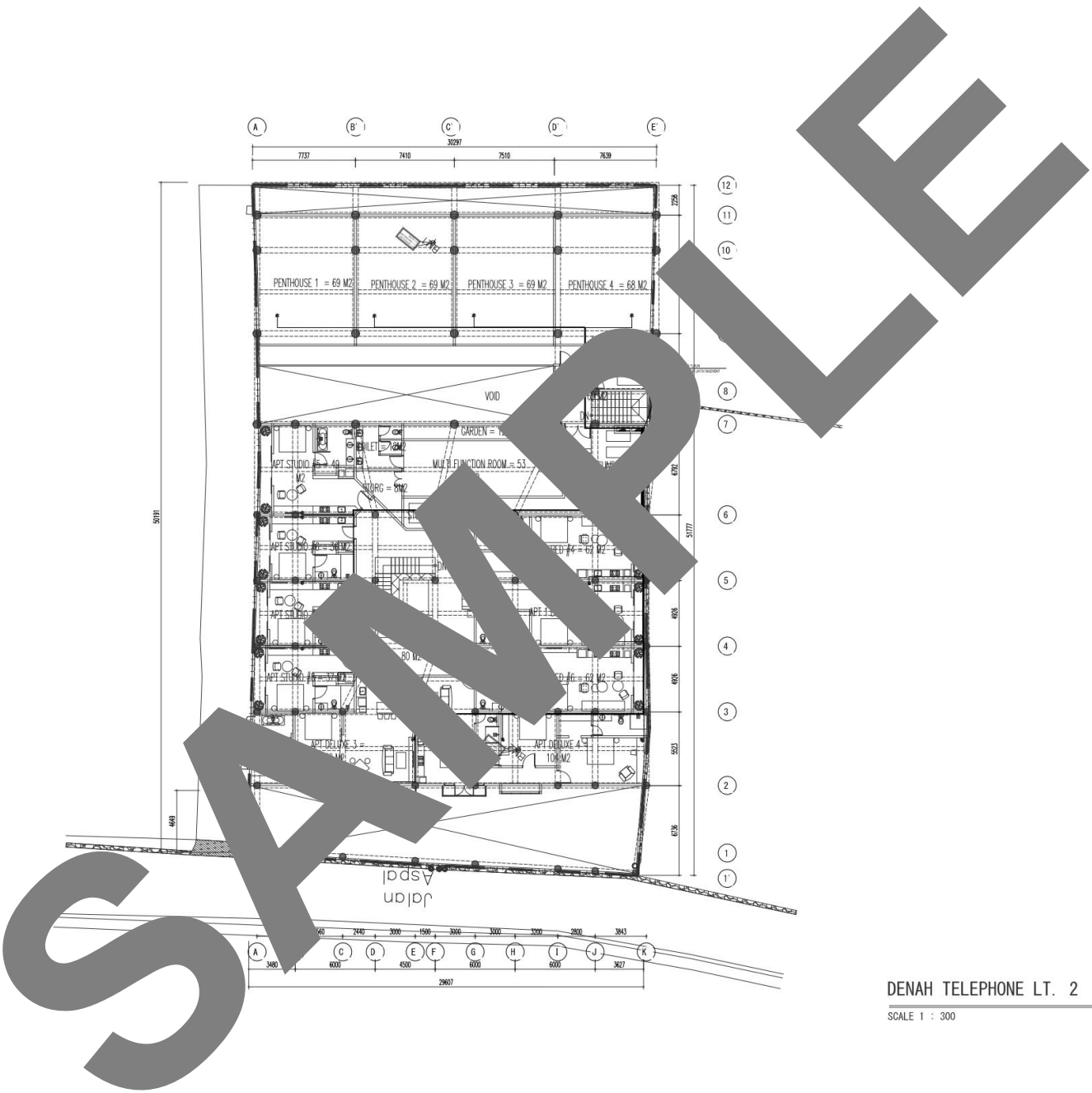

SYMBOLS	REMARKS
	OUTLET TELEPON LANGSUNG (R111) DIRECT TELEPHONE OUTLET (R111)
	OUTLET TELEPON EXTENSION (R111) EXTENSION TELEPHONE OUTLET (R111)
	PRIVATE AUTOMATIC BRANCH EXCHANGE PRIVATE AUTOMATIC BRANCH EXCHANGE

CATANAN :
 - INSTALASI TELEPON MENGGUNAKAN KABEL (TC 2x2x0,6 mm (KABEL TELEPON) DALAM HIGH IMPACT CONDUIT Ø20mm

NAMA PROJEK
 PROJECT NAME

SINI SANA APARTEMEN

NO	REVISI	REVISI	TANGGAL
NO	REVISI	BY	DATE

KONSULTAN PERENCANA
 CONSULTANT



PEMERINTAH TUGAS
 OWNER

STRUCTURE ENGINEER
 KONTROL

NAMA CORBAK
 DRAWING TITLE

DISENIBAR
 DESAIN BY: H. D.
 SKALA
 SCALE: AS - SHOWN
 TANGGAL
 DATE: 03 OKTOBER 2022

DENAH TELEPHONE LT. 2

SCALE 1 : 300

NO. PROJEK	KODE PROJEK	KODE GAMBAR
PROJECT NO.	PROJECT CODE	DRAWING CODE
		E. 2. 04
DEVELOPER/AN ORDER	NO. LEMBAR	TOTAL LEMBAR
ISSUED FOR	SHEET NO.	SHEET TOTAL
DETAILING ENGINEERING SECTION		

FIBER OPTIC SINGLE MODE 8 Core
IN PVC HI CONDUIT Ø 20mm
ON CABLE TRAY

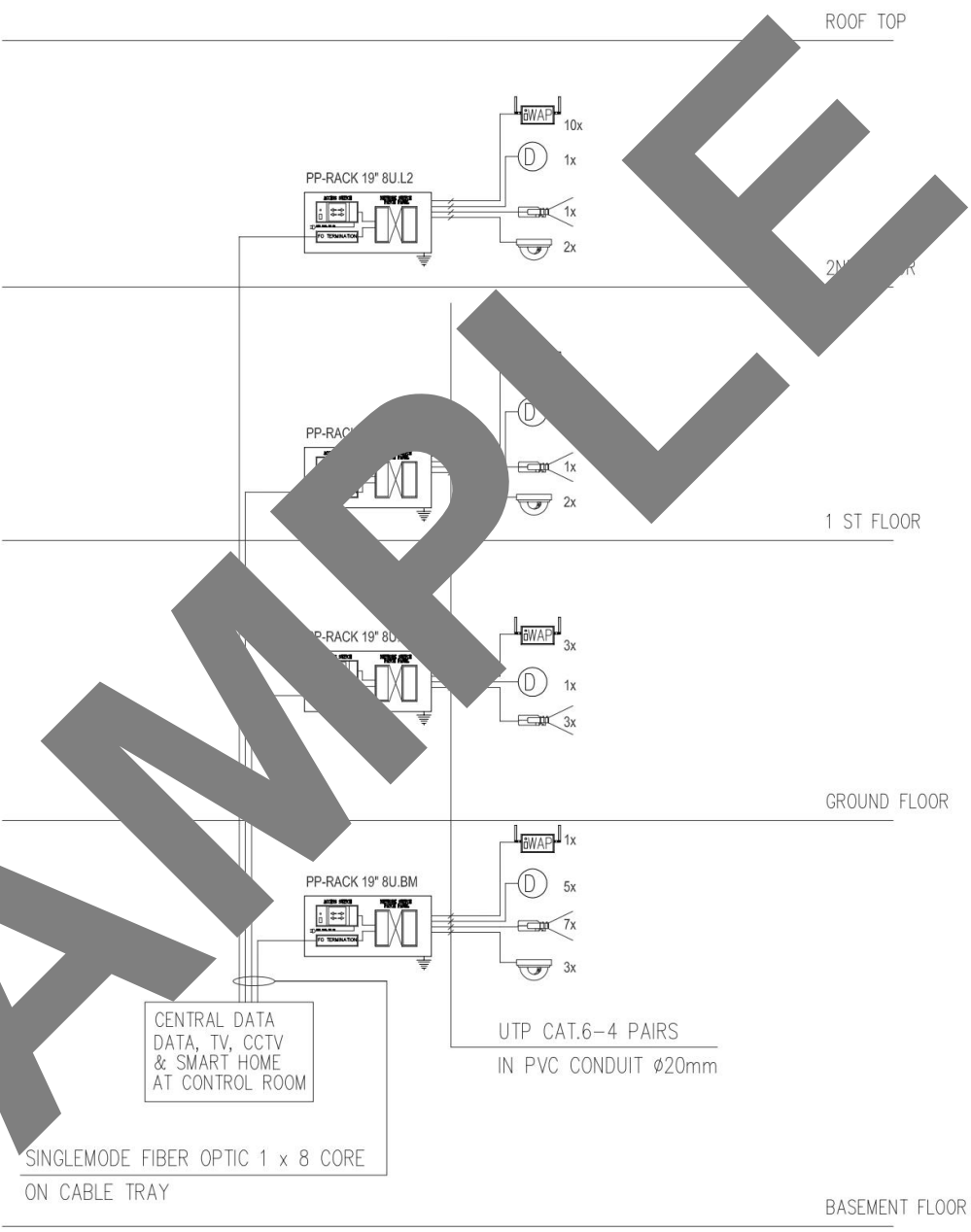
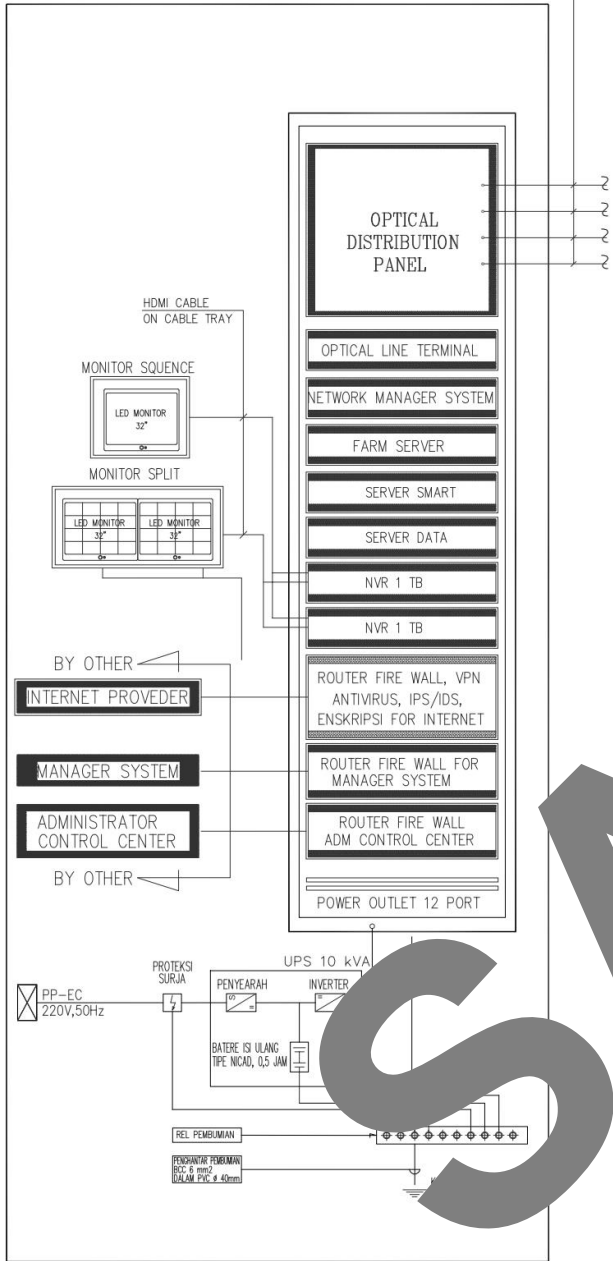

SYMBOLS	REMARKS
	CCTV DALAM RUANGAN TIPE DOME CCTV INDOOR DOME TYPE
	CCTV OUTDOOR TIPE BALET DENGAN FLEKUNG & LENS IRIS CCTV OUTDOOR WITH HOUSING & IRS LENS TIPE BALET
	RAK DINDING 19" WALL MOUNT RACK 19"
	OUTLET KABEL DATA (RJ45) DATA CABLE OUTLET (RJ45)
	OUTLET TELEVISI TELEVISION OUTLET
	AKSES DATA TANPA KABEL WIRELESS ACCESS POINT

CATATAN :

- INSTALASI CCTV MENGGUNAKAN KABEL UTP CAT 6 (KABEL CCTV) DALAM HIGH IMPACT CONDUIT Ø20mm
- INSTALASI DATA MENGGUNAKAN KABEL UTP CAT 6 (KABEL DATA) DALAM HIGH IMPACT CONDUIT Ø20mm

NO. PROJEK

PROJECT NAME

SINI SANA APARTEMEN

NO	REVISI	REVISI	TANGGAL
NO	REVISI	BY	DATE

KONSULTAN PERENCANA
CONSULTANT



PERENCANA / TUGAS
OWNER

STRUCTURE ENGINEER	STRUCTURE ENGINEER

NO. GAMBAR
DRAWING TITLE

DITAMBAH
DESKRIPSI

DESKRIPSI

SKALA
SCALE

TANGGAL
DATE

NO. PROJEK	KODE PROJEK	KODE GAMBAR
PROJECT NAME	PROJECT CODE	DRAWING CODE
E. 2.01		
DEVELOPER/OWNER	NO. LEMBAR	TOTAL LEMBAR
ISSUED FOR	SHEET NO.	SHEET TOTAL
DETAILING ENGINEERING SECTION		

DIAGRAM SISTEM CCTV & DATA
SCALE : NTS

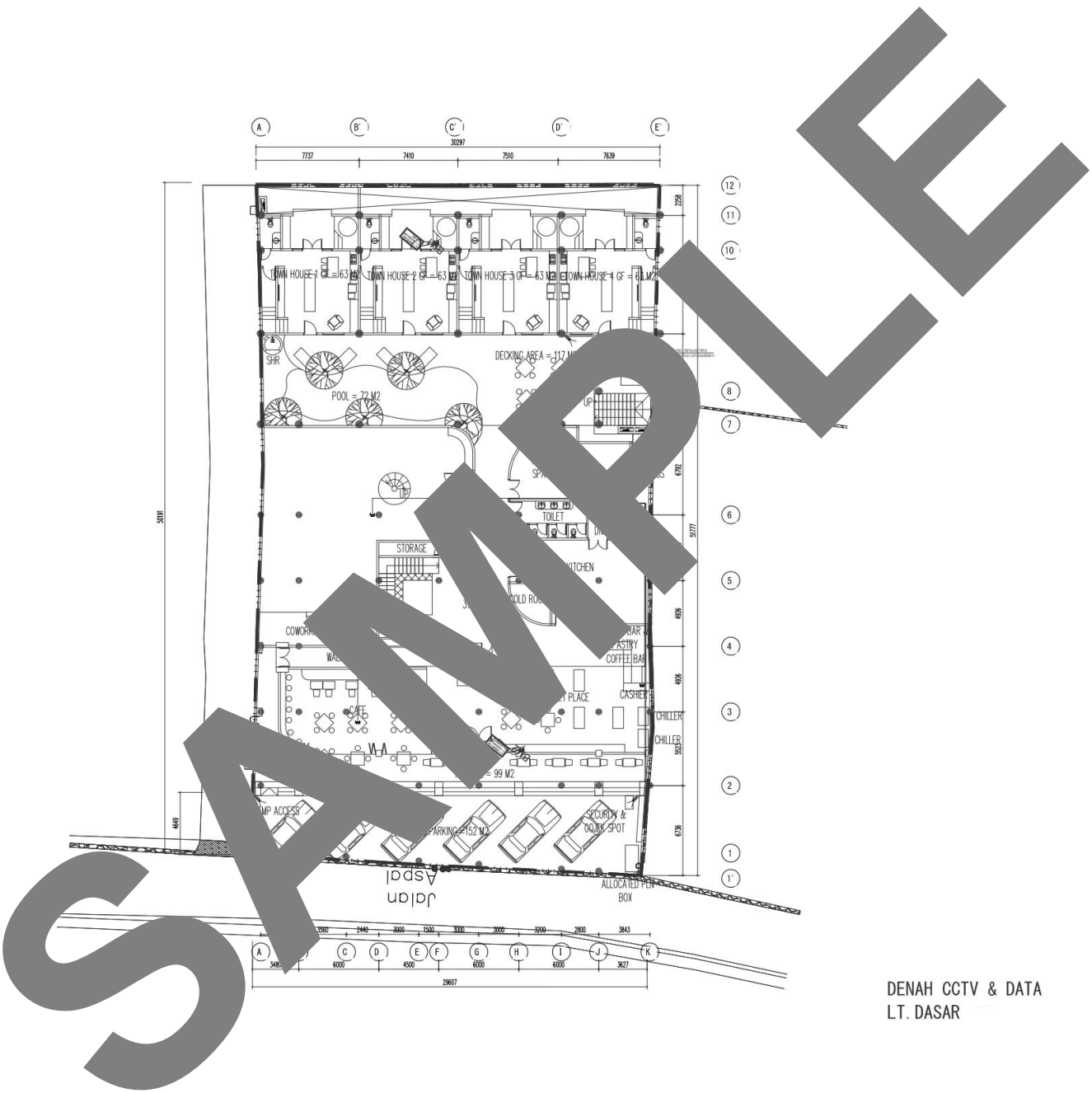

REVISION/ REFERENCE

SYMBOLS	REMARKS
	CCTV DALAM RUANGAN TIPE DOME CCTV INDOOR DOME TYPE
	CCTV OUTDOOR TIPE BALET DENGAN PENANGKAP & LENS CCTV OUTDOOR WITH HOUSING & RIS LENS TIPE BALET
	RAK DINDING 19" WALL MOUNT RACK: 19"
	OUTLET KABEL DATA (RJ45) DATA CABLE OUTLET (RJ45)
	OUTLET TELEVISI TELEVISION OUTLET
	ACCESS DATA TANPA KABEL WIRELESS ACCESS POINT

CATATAN :

- INSTALASI CCTV MENGGUNAKAN KABEL UTP CAT 6 (KABEL CCTV) DALAM HIGH IMPACT CONDUIT Ø20mm
- INSTALASI DATA MENGGUNAKAN KABEL UTP CAT 6 (KABEL DATA) DALAM HIGH IMPACT CONDUIT Ø20mm

NAMA PROJEK

PROJECT NAME

SINI SANA APARTEMEN

NO	REVISI	REVISI	TANGGAL
NO	REVISI/NO	BY	DATE

KONSULTAN PEKERJAAN
CONSULTANT



PT. PADMA BUMI GAREZA

PEMERINTAH TUGAS

OWNER

STRUCTURE ENGINEER STRUCTURE ENGINEER

NAMA CORBAK

DRAWING TITLE

DISUSUN OLEH	HE D
SKALA	AS - SHOWN
TANGGAL	03 OKTOBER 2022
DATE	

NO. PROJEK	KODE PROJEK	KODE GAMBAR
PROJECT NO.	PROJECT CODE	DRAWING CODE
		E. 2. 02

DEVELOPER/AN ORDER	NO LEMBAR	TOTAL LEMBAR
ISSUED FOR	SHEET NO.	SHEET TOTAL

DETAILING	ENGINEERING	SECTION

DENAH CCTV & DATA
LT. DASAR

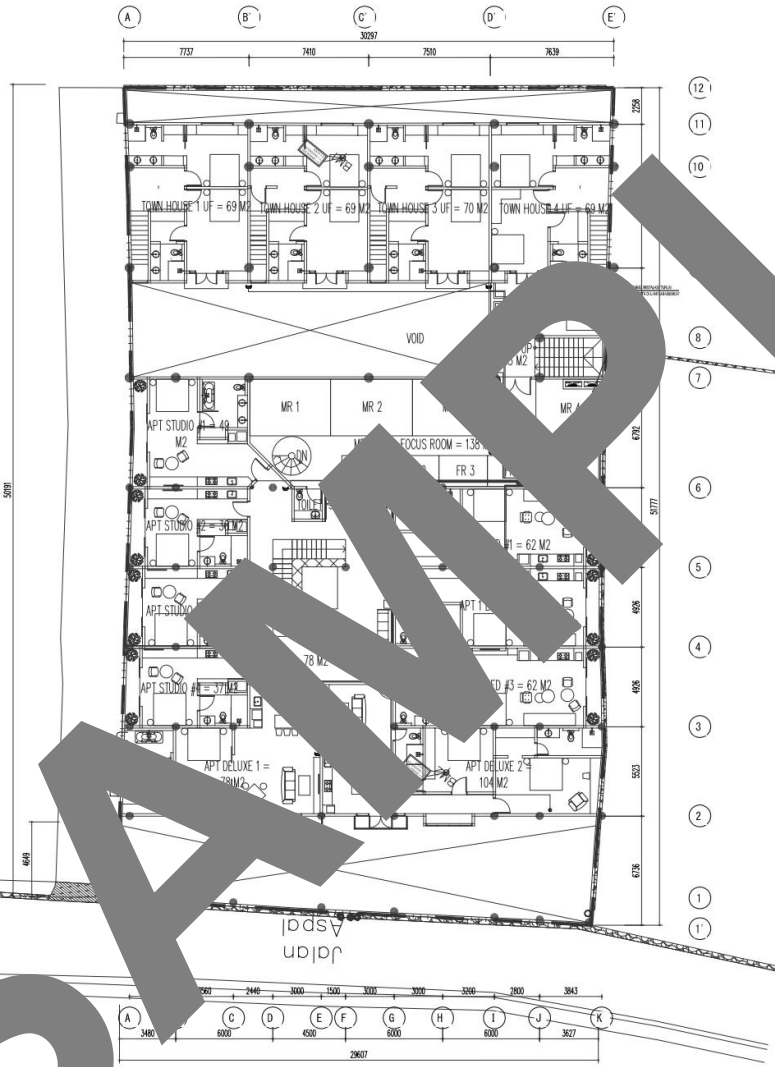

SYMBOLS	REMARKS
	CCTV DALAM RUANGAN TIPE DOME
	CCTV INDOOR DOME TYPE
	CCTV OUTDOOR TIPE BALET DENGAN PENANGKAP & LENSIS R/S
	CCTV OUTDOOR WITH HOUSING & R/S LENS TIPE BALET
	RAK DINDING 19"
	WALL MOUNT RACK 19"
	OUTLET KABEL DATA (RJ45)
	DATA CABLE OUTLET (RJ45)
	OUTLET TELEVISI
	TELEVISION OUTLET
	AKSES DATA TANPA KABEL
	WIRELESS ACCESS POINT

CATATAN :
 - INSTALASI CCTV MENGGUNAKAN KABEL LTP CAT 6 (KABEL CCTV) DALAM HIGH IMPACT CONDUIT Ø20mm
 - INSTALASI DATA MENGGUNAKAN KABEL LTP CAT 6 (KABEL DATA) DALAM HIGH IMPACT CONDUIT Ø20mm

NOMOR PROJEK
 PROJECT NAME

SINI SANA APARTEMEN

NO	REVISI	REVISI	TANGGAL
NO	REVISI	BY	DATE

KONSULTAN PERENCANA
 CONSULTANT



PEMERINTAH TUGAS
 OWNER

STRUCTURE ENGINEER
 KONSULTOR

NOMOR GAMBAR
 DRAWING TITLE

DITAMBAH
 DESAIN BY: H. D.
 SKALA
 SCALE: AS - SHOWN
 TANGGAL
 DATE: 03 OKTOBER 2022

NO. PROJEK	KODE PROJEK	KODE GAMBAR
PROJECT NAME	PROJECT CODE	DRAWING CODE
		E. 2. 03
DEVELOPER/AN ORDER	NO. LEMBAR	TOTAL LEMBAR
ISSUED FOR	SHEET NO.	SHEET TOTAL
DETAILING ENGINEERING SECTION		

DENAH CCTV & DATA LT. 1

SCALE 1 : 300

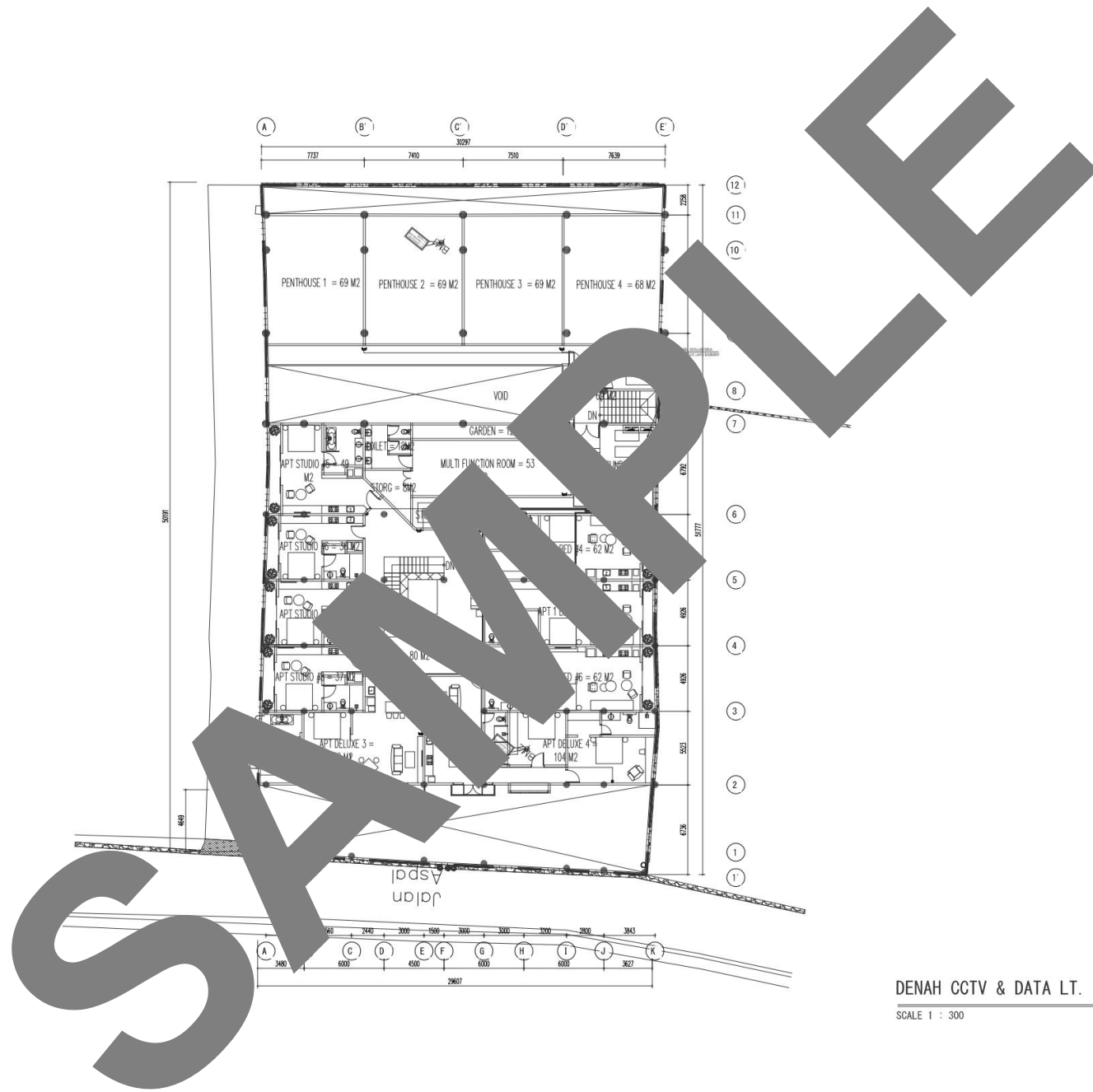

REVISION/ REFERENCE

SYMBOLS	REMARKS
	CCTV DALAM RUANGAN TIPE DOME CCTV INDOOR DOME TYPE
	CCTV OUTDOOR TIPE BALET DENGAN PENANGKAP & LENS IRIS CCTV OUTDOOR WITH HOUSING & IRS LENS TIPE BALET
	RAK DINDING 19" WALL MOUNT RACK 19"
	OUTLET KABEL DATA (RJ45) DATA CABLE OUTLET (RJ45)
	OUTLET TELEVISI TELEVISION OUTLET
	AKSES DATA TANPA KABEL WIRELESS ACCESS POINT

CATATAN :

- INSTALASI CCTV MENGGUNAKAN KABEL UTP CAT 6 (KABEL CCTV) DALAM HIGH IMPACT CONDUIT Ø20mm
- INSTALASI DATA MENGGUNAKAN KABEL UTP CAT 6 (KABEL DATA) DALAM HIGH IMPACT CONDUIT Ø20mm

NOMOR PROJEK
PROJECT NAME

SINI SANA APARTEMEN

NO	REVISI	REVISI	TANGGAL
NO	REVISI	BY	DATE

KONSULTAN PERENCANA
CONSULTANT



PT. PADMA BUMI GAREZA

PEMERINTAH TUGAS
OWNER

STRUCTURE ENGINEER
KONSULTOR

STRUCTURE ENGINEER

NOMOR GAMBAR
DRAWING TITLE

DISAMBAH	HE D
DIARAH	AS - SHOWN
TANGGAL	03 OKTOBER 2022
DATE	

NO. PROJEK PROJECT NAME	KODE PROJEK PROJECT CODE	KODE GAMBAR DRAWING CODE
		E. 2. 04
DEVELOPER/AN ORDER ISSUED FOR	NO LEMBAR SHEET NO	TOTAL LEMBAR SHEET TOTAL
DETAILING ENGINEERING SECTION		

DENAH CCTV & DATA LT. 2

SCALE 1 : 300

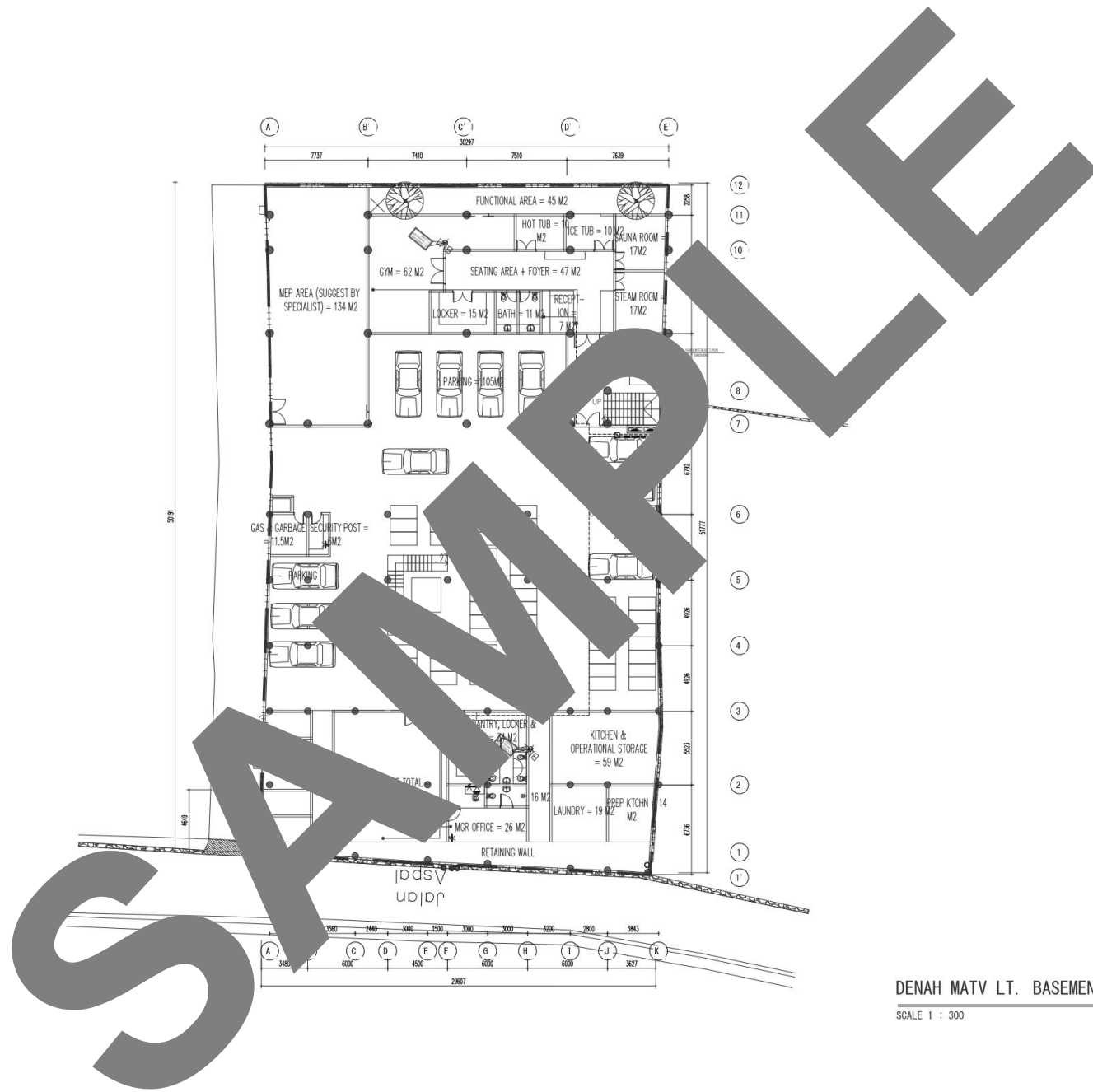

KETERANGAN REFERENSI			
NAMA PROJEK PROJECT NAME			
SINI SANA APARTEMEN			
NO	REVISI	REVISI	TANGGAL
NO	REVISI/DIM	BY	DATE
KONSULTAN PERENCANA CONSULTANT			
 PT. PADMA BUMI GAREZA			
PEMERINTAH TUGAS OWNER			
STRUCTURE ENGINEER KONSULTOR		STRUCTURE ENGINEER	
NAMA GAMBAR DRAWING TITLE			
DISEKSI/DIBAR	E. D		
DIBAR BY			
SKALA	AS - SHOWN		
TANGGAL	03 OKTOBER 2022		
DATE			
NO. PROYEK	KODE PROYEK	KODE GAMBAR	
PROJECT NAME	PROJECT CODE	DRAWING CODE	
		E. 2.01	
DEVELOPER/AN ORDER	NO LEMBAR	TOTAL LEMBAR	
ISSUED FOR	SHEET NO	SHEET TOTAL	
DETAILING ENGINEERING SECTION			

DENAH MATV LT. BASEMENT

SCALE 1 : 300

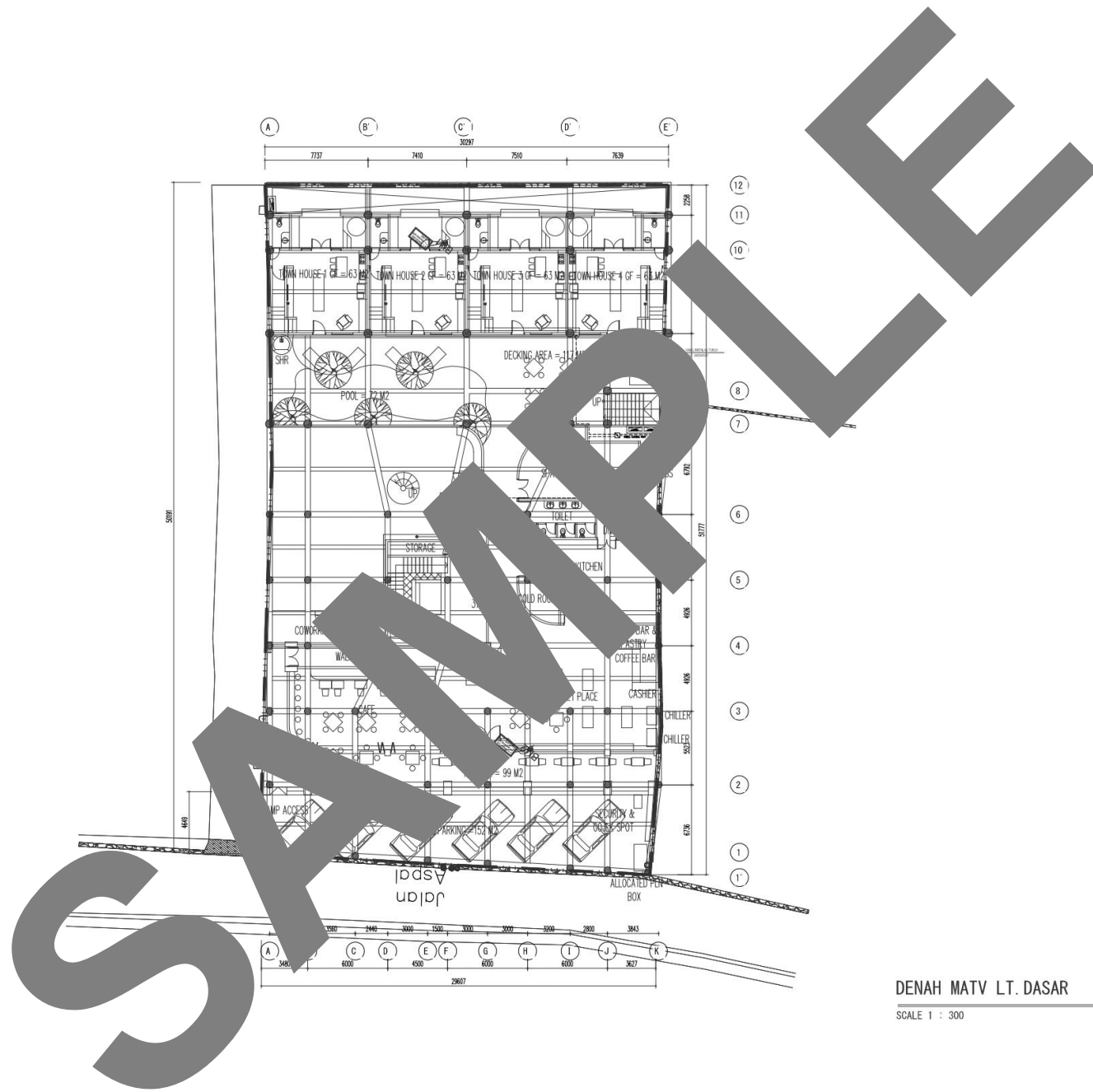

REVISION REFERENCE		
NAMA PROJEK PROJECT NAME SINI SANA APARTEMEN		
NO	REVISI	REVISI
NO	REVISI	DATE
KONSULTAN PERENCANA CONSULTANT		
 PT. PADMA BUMI GAREZA		
PEMERINTAH OWNER		
STRUCTURE ENGINEER	STRUCTURE ENGINEER	
NAMA GAMBAR DRAWING TITLE		
DISAMBAH DRAW BY	E. D	
SKALA SCALE	AS - SHOWN	
TANGGAL DATE	03 OKTOBER 2022	
NO. PROJEK PROJECT NO.	KODE PROJEK PROJECT CODE	KODE GAMBAR DRAWING CODE
		E. 2. 02
DEVELOPER/OWNER	NO. LEMBAR SHEET NO.	TOTAL LEMBAR SHEET TOTAL
DETAILING ENGINEERING SECTION		

DENAH MATV LT. DASAR

SCALE 1 : 300

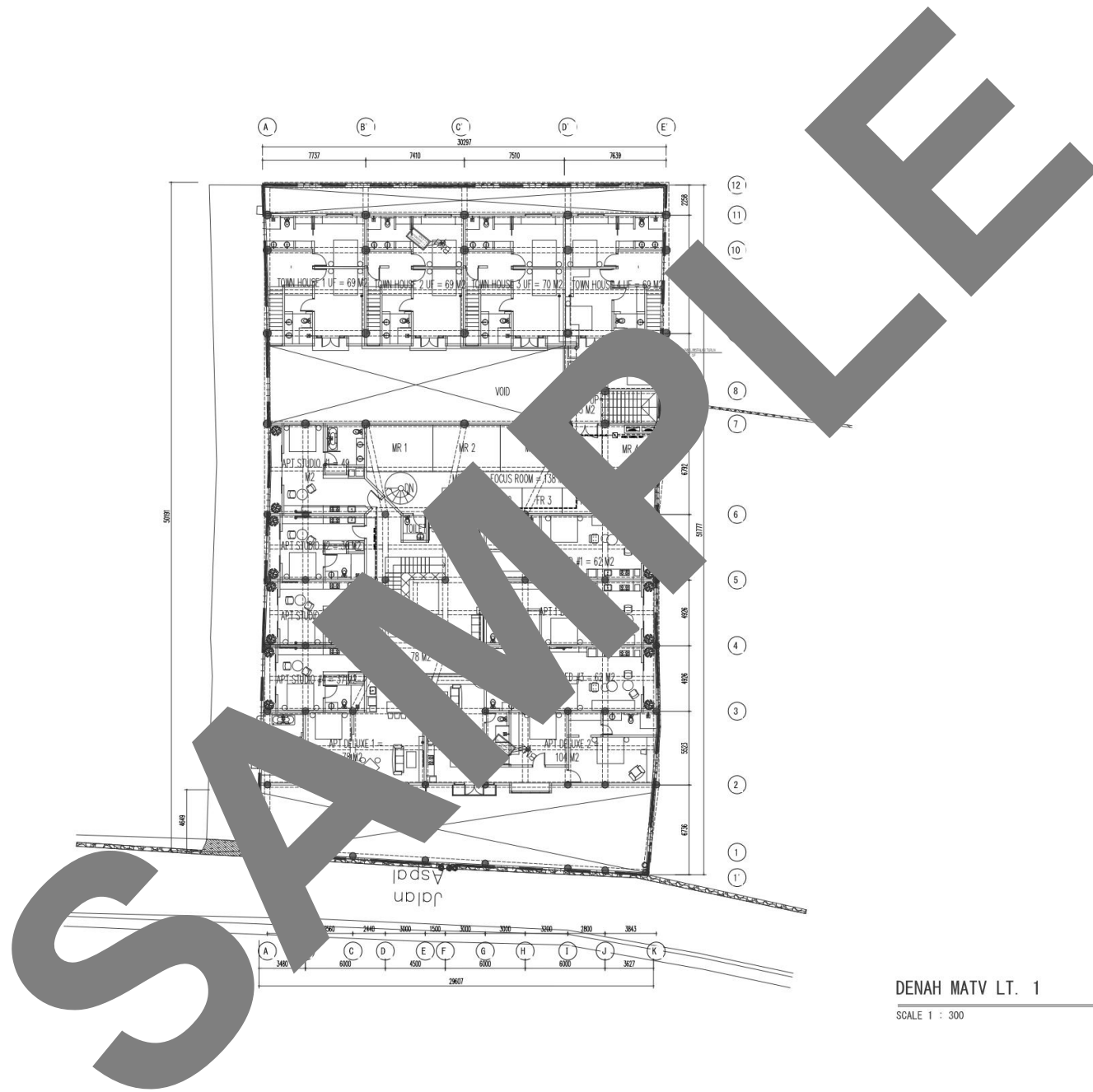

REVISION REFERENSI		
NAMA PROJEK PROJECT NAME		
SINI SANA APARTEMEN		
NO	REVISI	REVISI
NO	REVISI	REVISI
KONSULTAN PERENCANA CONSULTANT		
		
PEMERINTAH TUGAS OWNER		
STRUCTURE ENGINEER	STRUCTURE ENGINEER	
NAMA GAMBAR DRAWING TITLE		
DISEKSI	E. D	
DIBAR	AS - SHOWN	
TANGGAL	03 OKTOBER 2022	
NO. PROJEK	KODE PROJEK	KODE GAMBAR
PROJECT NO.	PROJECT CODE	DRAWING CODE
		E. 2. 03
DEVELOPER/OWNER	NO. LEMBAR	TOTAL LEMBAR
ISSUED FOR	SHEET NO.	SHEET TOTAL
DETAILING ENGINEERING SECTION		

DENAH MATV LT. 1

SCALE 1 : 300

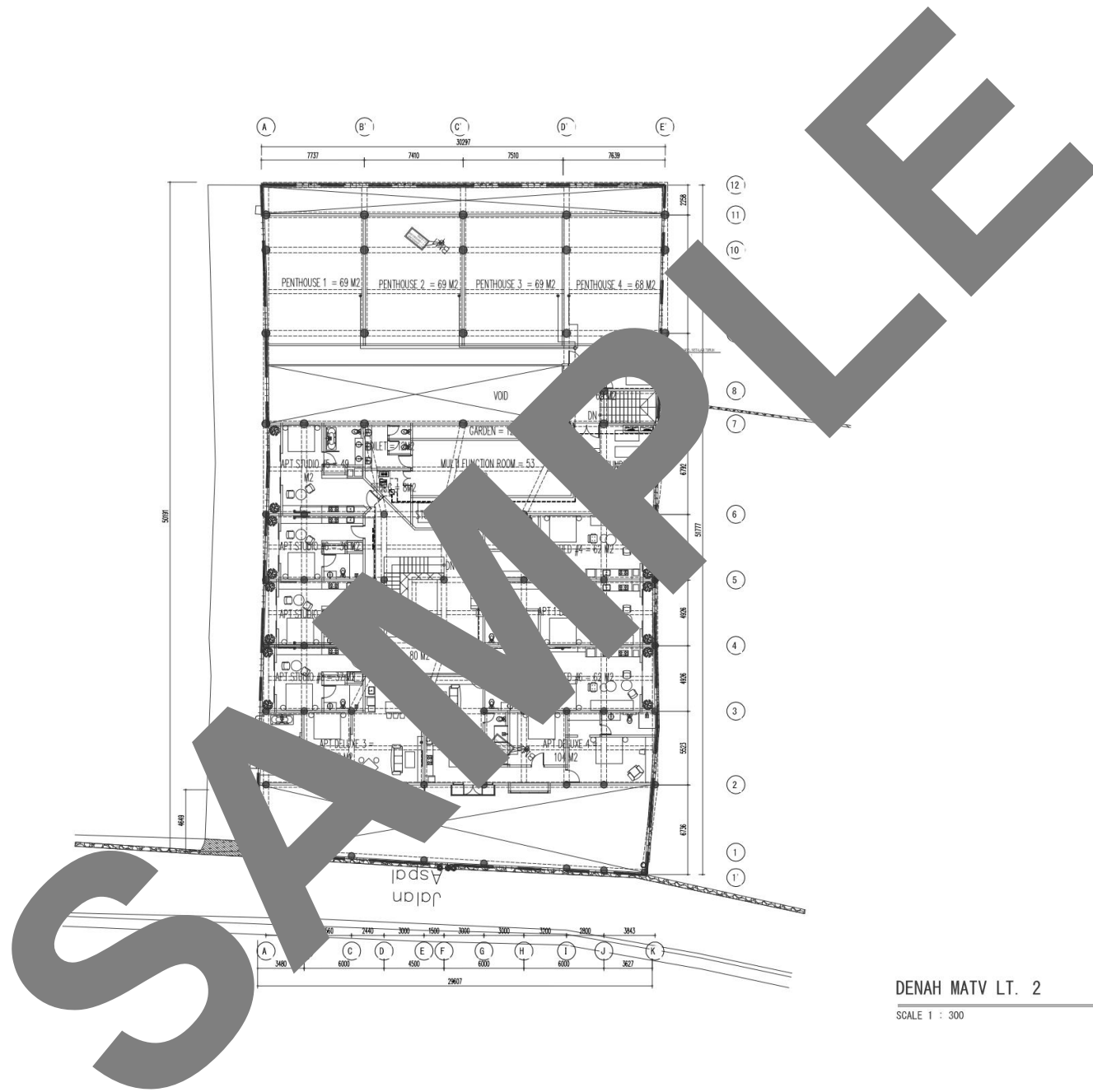

DENAH MATV LT. 2

SCALE 1 : 300

REVISI REVISION		
NAMA PROJEK PROJECT NAME		
SINI SANA APARTEMEN		
NO. REVISI	REVISI	TANGGAL
NO. REVISI	REVISI	DATE
KONSULTAN PERENCANA CONSULTANT		
 PT. PADMA BUMI GAREZA		
PEMERINTAH TUGAS OWNER		
STRUCTURE ENGINEER	STRUCTURE ENGINEER	
NAMA GAMBAR DRAWING TITLE		
DISENIBAR	E. D	
DESKRIPSI	AS - SHOWN	
TANGGAL	03 OKTOBER 2022	
DATE		
NO. PROJEK	KODE PROJEK	KODE GAMBAR
PROJECT NO.	PROJECT CODE	DRAWING CODE
		E. 2. 04
DEVELOPER/OWNER	NO. LEMBAR	TOTAL LEMBAR
ISSUED FOR	SHEET NO.	SHEET TOTAL
DETAILING ENGINEERING SECTION		

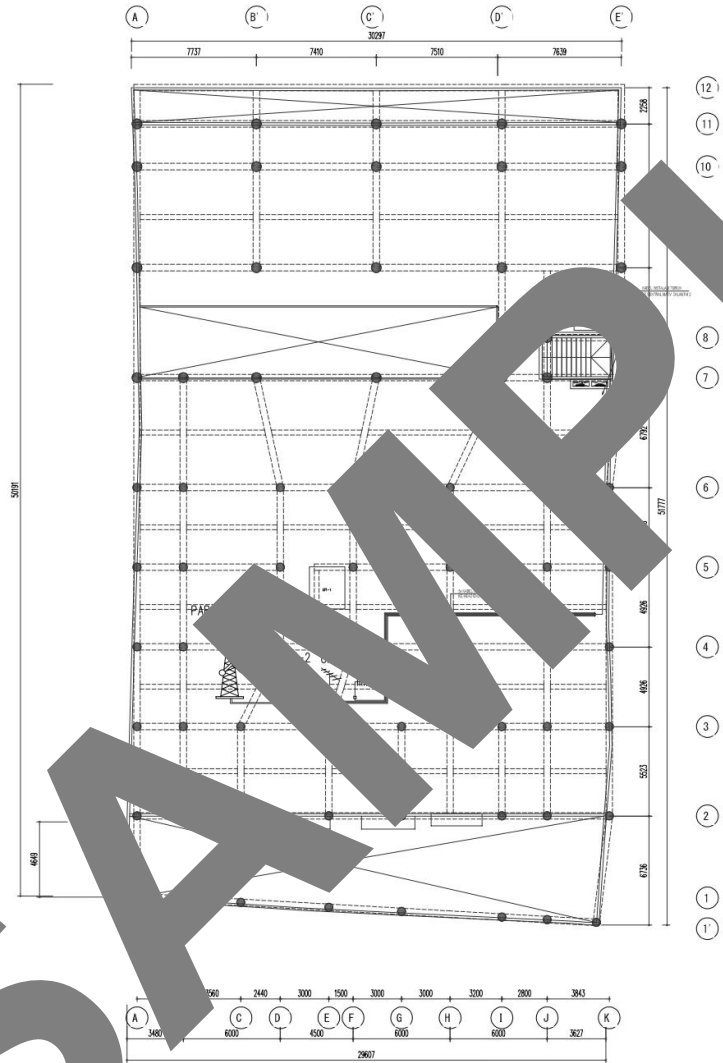

DENAH MATV ATAP

SCALE 1 : 300

REVISI

REVISIONS

NAMA PROJEK

PROJECT NAME

SINI SANA APARTEMEN

NO	REVISI	REG	TANGGAL
NO	REVISION	BY	DATE

KONSULTAN PERENCANA
CONSULTANT



PT. PADMA BUMI QAREZA

PEMERIKSA TUGAS

OWNER

STRUCTURE ENGINEER
SENIOR

Arifin Budhi Pratomo, S.T., M.Sc.

STRUCTURE ENGINEER

Subi Munawar, S.T.

NAMA GAMBAR

DRAWING TITLE

DICAMBAH

H. D.

SEAR BY

AS - SHOWN

SKALA

AS - SHOWN

TANGGAL

03 OKTOBER 2022

NO. PROJEK

KODE GAMBAR

PROJECT NO.

PROJECT CODE

NO. LEMBAR

KODE LEMBAR

ISSUED FOR

SHEET NO.

DETAIL NO.

SHEET TOTAL

ENGINEERING SECTION

SHEET TOTAL

E. 2. 04